

Midtown Hattiesburg **Form-Based Code**

prepared for

the City of Hattiesburg

Adopted: June 02, 2013

Contents

Article 1. General Provisions

Sec. 1.1. Purpose	1
Sec. 1.2. Intent.	1
Sec. 1.3. Applicability	1
Sec. 1.4. Transitional Provisions	1

Article 2. Districts

Sec. 2.1. Zoning Districts Established	2
Sec. 2.2. Midtown Form-Based Code Zoning Map	3
Sec. 2.3. Mixed Use Districts (MX-3, -4, -5)	4
Sec. 2.4. Employment Districts (EM-2, -3, -4, -6, -9).	5
Sec. 2.5. Residential Attached District (RA-3)	6
Sec. 2.6. Residential Detached District (RD-2).	7
Sec. 2.7. Open Space District (OS)	8

Article 3. Building Types

Sec. 3.1. Building Types Established	9
Sec. 3.2. Building Types Allowed by District.	11
Sec. 3.3. Mixed Use Building	12
Sec. 3.4. Shopfront Building.	14
Sec. 3.5. General Building.	16
Sec. 3.6. Civic Building	18
Sec. 3.7. Apartment Building	20
Sec. 3.8. Apartment Court.	22
Sec. 3.9. Garden Apartment.	24
Sec. 3.10. Stacked Flat.	26
Sec. 3.11. Townhouse	28
Sec. 3.12. Cottage Court	30
Sec. 3.13. Detached House	32
Sec. 3.14. Special Rules for the OS District	34
Sec. 3.15. Special Rules for the -HS Overlay District	35
Sec. 3.16. Building Elements	36
Sec. 3.17. Rules for All Building Types.	39

Article 4. Land Use

Sec. 4.1. Permitted Uses.	47
Sec. 4.2. Principal Uses	47
Sec. 4.3. Accessory Uses.	47
Sec. 4.4. Permitted Use Table	48
Sec. 4.5. Use Definitions.	50

Article 5. Site Development

Sec. 5.1. Parking	54
Sec. 5.2. Landscaping and Screening	60
Sec. 5.3. Signs	64
Sec. 5.4. Site Lighting	79
Sec. 5.5. Outdoor Display and Storage	82

Article 6. Streets

Sec. 6.1. General Provisions	84
Sec. 6.2. Midtown Future Street Map	85
Sec. 6.3. Street Types	86

Article 7. Administration

Sec. 7.1. Midtown Development Review Committee	91
Sec. 7.2. Deviations from the Code	91
Sec. 7.3. Nonconformities	92

Article 8. Definitions

Sec. 8.1. General Provisions	95
Sec. 8.2. Defined Terms	95

CODE STUDIO

1200 E. 11th Street, #107
Austin, TX 78702
(512) 478-2200
www.code-studio.com

Article 1. General Provisions

Sec. 1.1. Purpose

- A. The purpose of the Midtown Form-Based Code is to implement the Midtown Master Plan by amending the Hattiesburg Land Development Code.
- B. Specifically, the Midtown Form-Based Code provides the means to guide implementation of the citizen-endorsed vision for property within Midtown.
- C. The Midtown Form-Based Code fosters predictable results and a high-quality public realm by prescribing the physical form of buildings and other elements and addressing the relationship between building facades and the public realm, the form and mass of buildings in relation to one another and the scale and types of streets and blocks.

Sec. 1.2. Intent

It is the intent of the Midtown Form-Based Code to:

- A. Encourage better design in terms of building form and materials;
- B. Foster a variety of uses;
- C. Promote additional housing opportunities;
- D. Enable under-utilized or vacant properties;
- E. Make streets more bike and pedestrian-friendly;
- F. Enhance bike and pedestrian connections;
- G. Improve vehicular circulation;
- H. Enhance stormwater management;
- I. Create and maintain an urban forest;
- J. Promote the use of green building techniques;
- K. Support existing businesses and Institutions; and
- L. Ensure adequate transitions from Midtown to adjacent residential neighborhoods.

Sec. 1.3. Applicability

A. Territorial Application

The Midtown Form-Based Code applies to all property located within the Midtown District, as designated in *Sec. 2.2. Midtown Form-Based Code Zoning Map*.

B. Conflicting Provisions

1. Whenever any provision of a state statute or federal law imposes a greater requirement or a higher

standard than required by the Midtown Form-Based Code, the provision of the state statute or federal law governs.

2. Conflicts between the Midtown Form-Based Code and any other City ordinance or regulation must be resolved in favor of the intent of this Code.

Sec. 1.4. Transitional Provisions

A. New Development

1. Except as provided in *Sec. 1.4.C* below, upon the effective date of the Midtown Form-Based Code or any subsequent amendment, any new building or other structure or any use of land must be constructed or developed only in accordance with all applicable provisions of the Midtown Form-Based Code.
2. No excavation or filling of land or construction of any public or private improvements may take place or commence except in conformity with the Midtown Form-Based Code.

B. Existing Development

Except as provided in *Sec. 1.4.C* below, any existing use, lot, building or other structure legally established prior to the effective date of the Midtown Form-Based Code that does not comply with any provision of the Midtown Form-Based Code are subject to the provisions of *Sec. 7.3. Nonconformities*.

C. Previously Issued Permits and Pending Applications

1. Any building permit issued before the effective date of the Midtown Form-Based Code or subsequent amendment remains in effect.
2. The provisions of Midtown Form-Based Code do not apply to zoning and subdivision applications that are complete and pending at the effective date of this Code.
3. Pending applications will be processed in accordance with and decided pursuant to the law existing on the date the application was filed.

Article 2. Districts

Sec. 2.1. Zoning Districts Established

The following Midtown Districts are established.

A. Mixed Use Districts (MX-)

1. The MX- Districts are intended to accommodate a mix of compatible commercial, employment and higher-density residential in a pedestrian-friendly and walkable environment.
2. The MX- Districts vary based on the maximum allowed building height.
 - a. MX-3 has a maximum building height of 3 stories.
 - b. MX-4 has a maximum building height of 4 stories.
 - c. MX-5 has a maximum building height of 5 stories.

B. Employment Districts (EM-)

1. The EM- Districts are intended to accommodate a mix of compatible office, medical and medium-density residential in a pedestrian-friendly and walkable environment.
2. The EM- Districts vary based on the maximum allowed building height.
 - a. EM-2 has a maximum building height of 2 stories.
 - b. EM-3 has a maximum building height of 3 stories.
 - c. EM-4 has maximum building height of 4 stories.
 - d. EM-6 has a maximum building height of 6 stories.
 - e. EM-9 has a maximum building height of 9 stories.

C. Residential Attached District (RA-3)

1. The RA-3 District is intended to accommodate a mix of medium-density detached and attached residential in a pedestrian-friendly and walkable environment.
2. RA-3 has a maximum building height of 3 stories.

D. Residential Detached District (RD-2)

1. The RD-2 District is intended to accommodate a mix of lower-density detached residential in a pedestrian-friendly and walkable environment.
2. RD-2 has a maximum building height of 2 stories.

E. Open Space District (OS)

The OS District is intended to accommodate greens, plazas and parks.

F. Hardy Street Overlay (-HS)

1. The -HS Overlay District is intended to enhance and promote Hardy Street as the key pedestrian corridor in Midtown.
2. Where the -HS Overlay District applies, the underlying district requirements must be met except as expressly modified in *Sec. 3.15. Special Rules for the -HS Overlay District.*

Sec. 2.2. Midtown Form-Based Code Zoning Map

The following map is established and made a part of the City of Hattiesburg Official Zoning Map.

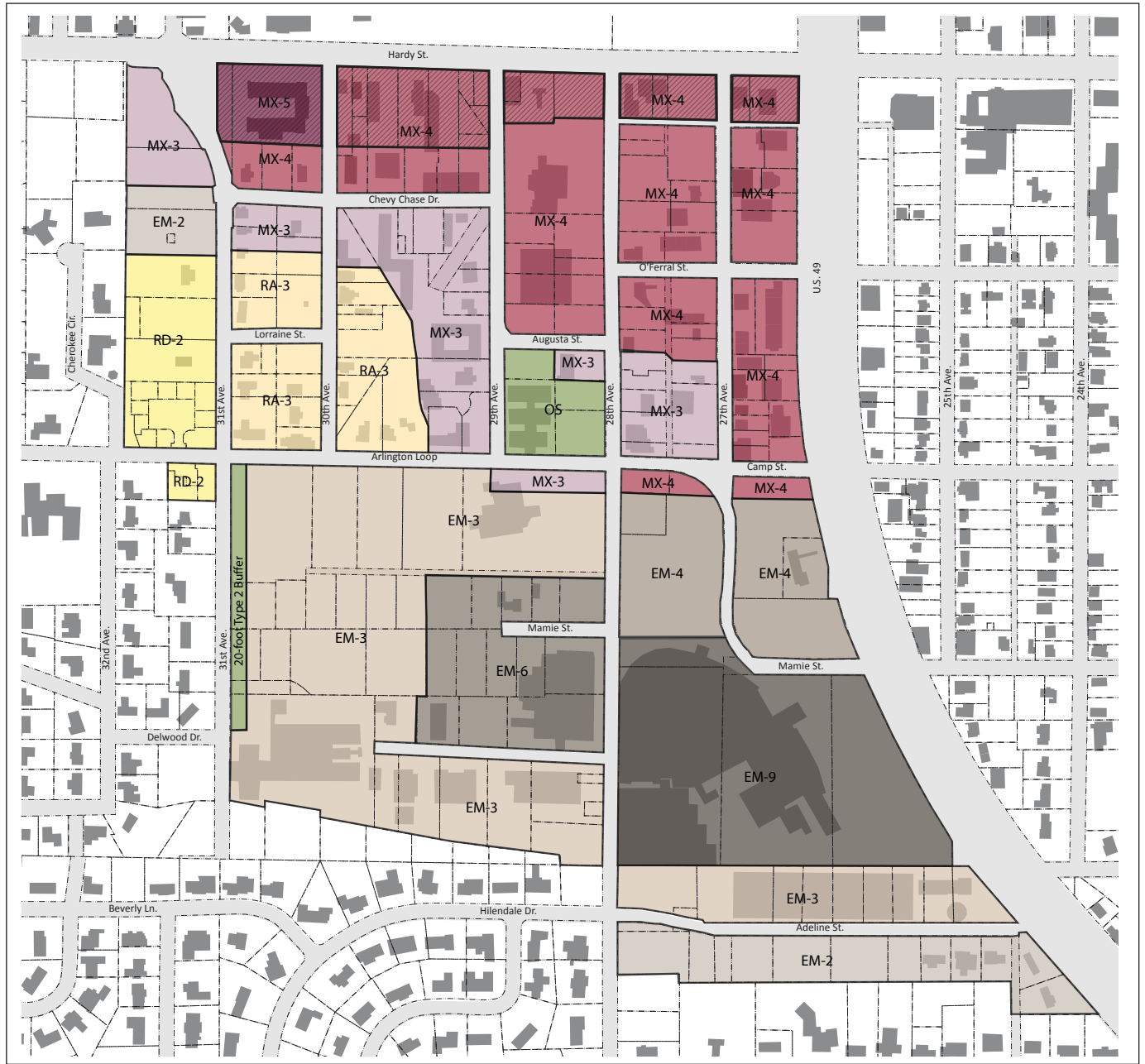

Mixed Use

- MX-3: Mixed Use 3-Story
- MX-4: Mixed Use 4-Story
- MX-5: Mixed Use 5-Story

Employment

- EM-2: Employment 2-Story
- EM-3: Employment 3-Story
- EM-4: Employment 4-Story
- EM-6: Employment 6-Story
- EM-9: Employment 9-Story

Residential

- RD-2: Detached 2-Story
- RA-3: Attached 3-Story

Open Space

- OS: Open Space

Overlay

- HS: Hardy Street Overlay

Sec. 2.3. Mixed Use Districts (MX-3, -4, -5)

The MX- Districts are intended to accommodate a mix of compatible commercial, employment and higher-density residential in a pedestrian-friendly and walkable environment.

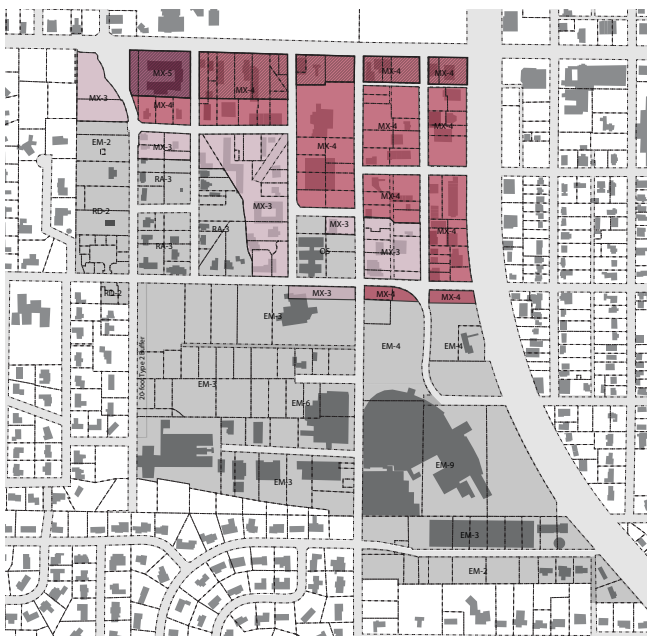

A. Permitted Building Types

- | | |
|----------------------|--------------------|
| ■ Mixed Use Building | ■ Garden Apartment |
| ■ Shopfront Building | ■ Stacked Flat |
| ■ General Building | ■ Townhouse |
| ■ Civic Building | ■ Cottage Court |
| ■ Apartment Building | ■ Detached House |
| ■ Apartment Court | |

Sec. 2.4. Employment Districts (EM-2, -3, -4, -6, -9)

The EM- Districts are intended to accommodate a mix of compatible office, medical and medium-density residential in a pedestrian-friendly and walkable environment.

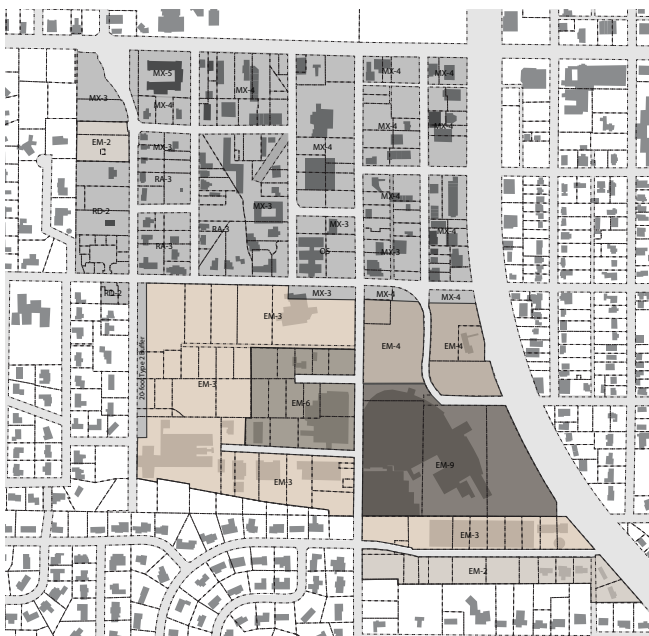

A. Permitted Building Types

EM-2, -3	EM-4, -6, -9
General Building	General Building
Civic Building	Civic Building
Apartment Building	Apartment Building
Apartment Court	Apartment Court
Garden Apartment	Garden Apartment
Stacked Flat	Stacked Flat
Townhouse	Townhouse
Cottage Court	Cottage Court
Detached House	Detached House

Sec. 2.5. Residential Attached District (RA-3)

The RA-3 District is intended to accommodate a mix of medium-density detached and attached residential in a pedestrian-friendly and walkable environment.

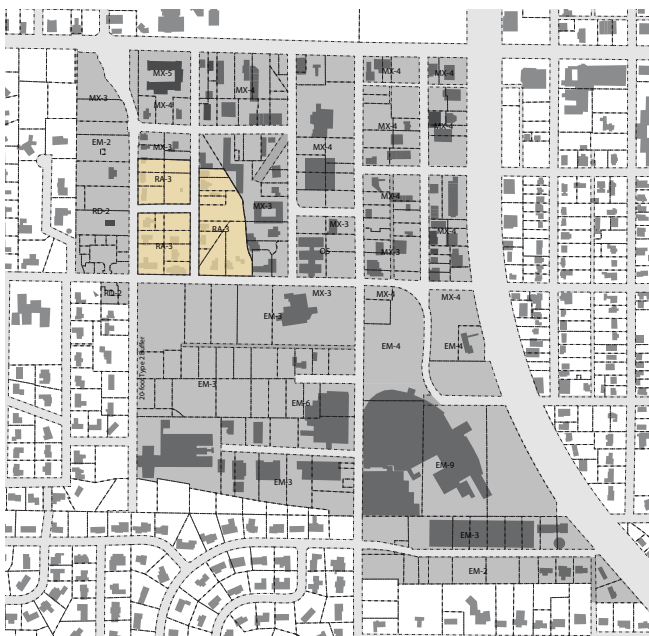

A. Permitted Building Types







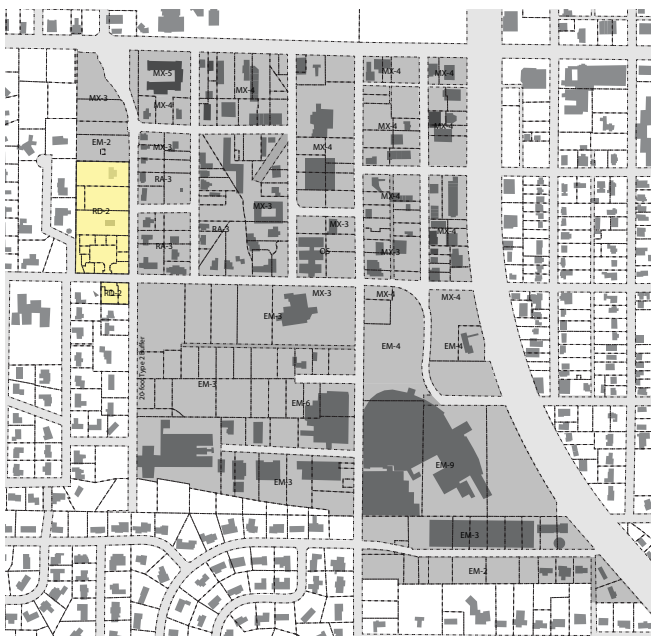



- | | |
|----------------------|--------------------|
| ■ Mixed Use Building | ■ Garden Apartment |
| ■ Shopfront Building | ■ Stacked Flat |
| ■ General Building | ■ Townhouse |
| ■ Civic Building | ■ Cottage Court |
| ■ Apartment Building | ■ Detached House |
| ■ Apartment Court | |

Sec. 2.6. Residential Detached District (RD-2)

The RD-2 District is intended to accommodate a mix of lower-density detached residential in a pedestrian-friendly and walkable environment.



A. Permitted Building Types

- | | |
|--|--|
|  Mixed Use Building |  Garden Apartment |
|  Shopfront Building |  Stacked Flat |
|  General Building |  Townhouse |
|  Civic Building |  Cottage Court |
|  Apartment Building |  Detached House |
|  Apartment Court | |

Sec. 2.7. Open Space District (OS)

The OS District is intended to accommodate civic greens, plazas and parks and is characterized by both active and passive uses.

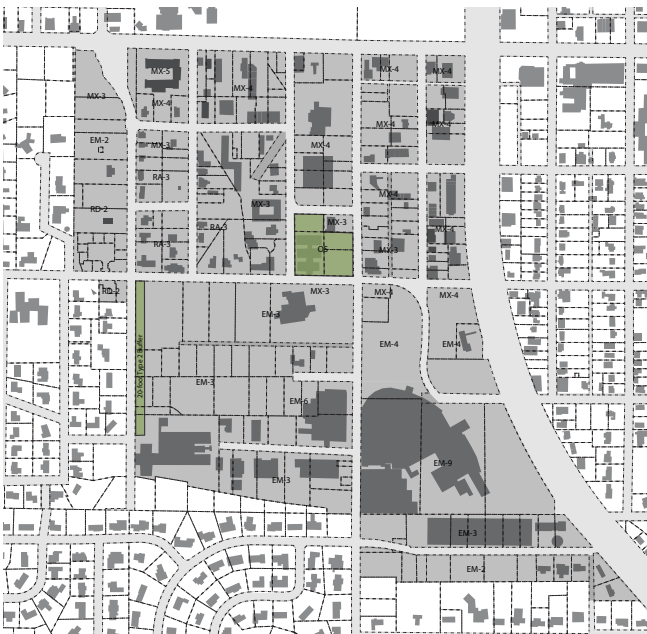

A. Permitted Building Types

The OS District is regulated by Sec. 3.14. *Special Rules for the OS District.*

Article 3. Building Types

Sec. 3.1. Building Types Established

This section establishes and defines each building type to ensure that proposed development is consistent with the district goals for building form, physical character, land use and quality.

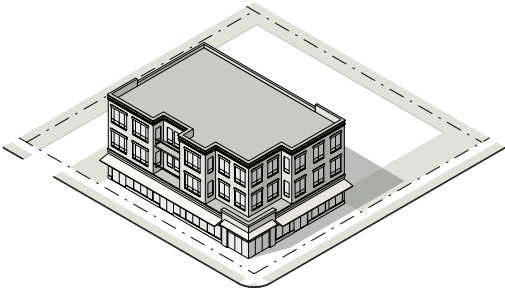

A. Mixed Use Building

A multi-story building type that typically accommodates ground floor retail uses with upper-story residential or commercial use. Not intended for ground floor residential use.

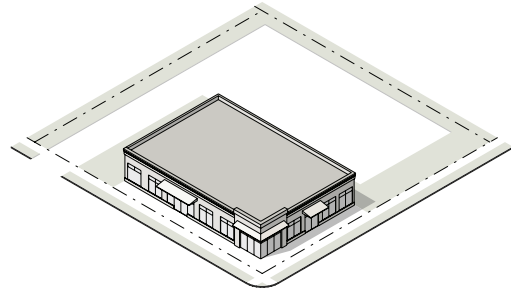

B. Shopfront Building

A single-story building type that typically accommodates ground floor retail uses. Not intended for residential use.

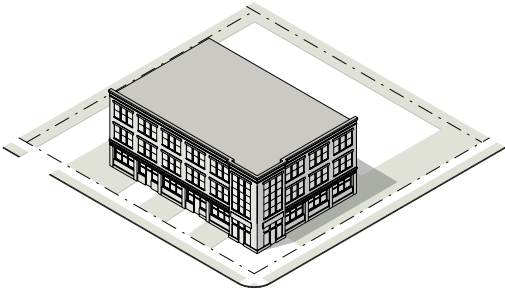

C. General Building

A building type that typically accommodates commercial uses. Not intended for retail or residential use.

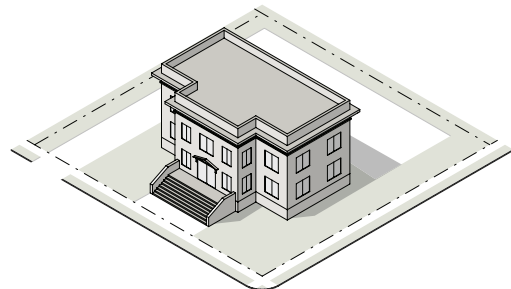

D. Civic Building

A building type that accommodates specifically identified civic uses (see *Sec. 3.6. Civic Building*). Not intended for retail, commercial or residential uses.

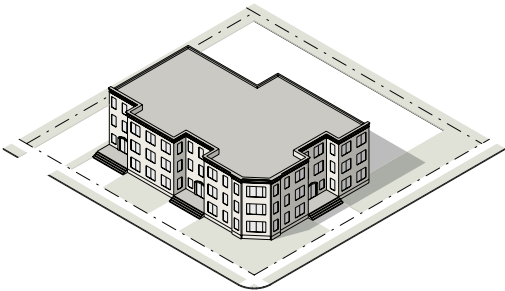

E. Apartment Building

A building type that accommodates 12 or more attached dwelling units vertically and horizontally integrated. Not intended for non-residential use.

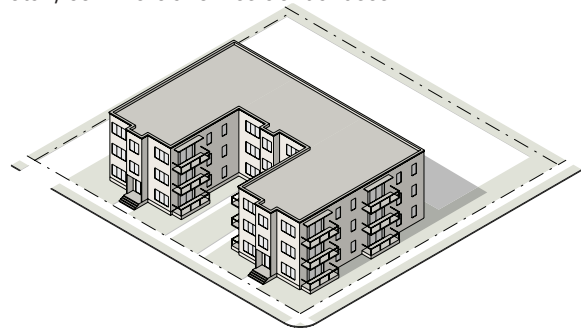

F. Apartment Court

A building type that accommodates 12 or more attached dwelling units vertically and horizontally integrated and organized around a courtyard that fronts a primary street. Not intended for non-residential use.

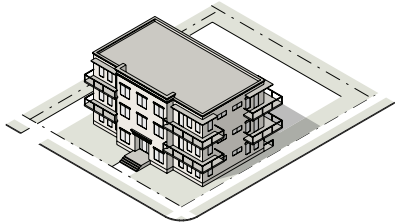

G. Garden Apartment

A building type that accommodates 3 to 12 attached dwelling units vertically and horizontally integrated. Not intended for non-residential use.

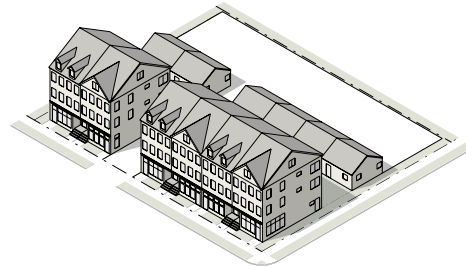

H. Stacked Flat

A multi-story building type that accommodates side-by-side attached units where units can be used for both non-residential and residential use. Ground floor units can be separated from upper-story units or units can be internally connected.

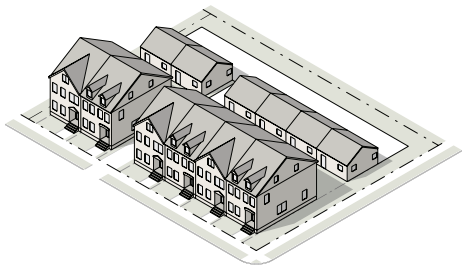

I. Townhouse

A building type that accommodates 3 or more dwelling units where each unit is separated vertically by a common side wall. Units cannot be vertically mixed. Not intended for non-residential uses.

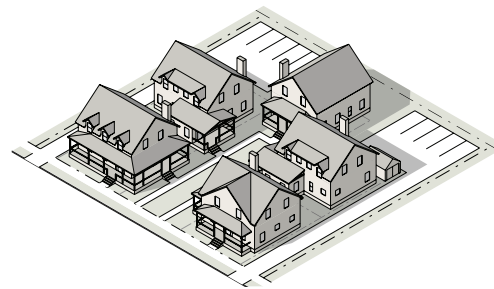

J. Cottage Court

A development building type with 5 to 9 detached houses and organized around a common courtyard that fronts a primary street. Not intended for non-residential uses.







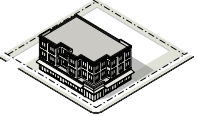
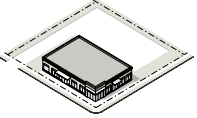
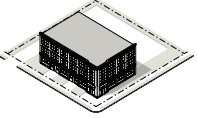

K. Detached House

A building type that accommodates one dwelling unit on an individual lot with yards on all sides along with a rear accessory dwelling unit at grade or above a garage (carriage house). Not intended for non-residential uses.

Sec. 3.2. Building Types Allowed by District

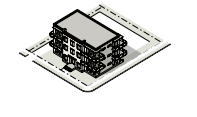
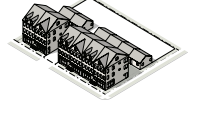
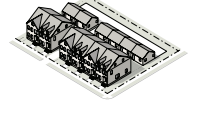
Building types are allowed by district as set forth below.

BUILDING TYPE	Mixed Use (MX-3, -4, -5)	Hardy Street Overlay (-HS)	Employment (EM-2, -3)	Employment (EM-4, -6, -9)	Residential Attached (RA-3)	Residential Detached (RD-2)
 Mixed Use Building	P	P				
 Shopfront Building	P	P				
 General Building	P	P	P	P		
 Civic Building	P	P	P	P	P	P
 Apartment Building	P		P			
 Apartment Court	P		P			
 Garden Apartment	P		P		P	
 Stacked Flat	P		P		P*	
 Townhouse	P		P		P	
 Cottage Court					P	P
 Detached House					P	P

Key: P = Permitted Blank Cell = Not Permitted

* In RA-3, a stacked flat is only allowed on a lot located at the intersection of two public streets.

Sec. 3.3. Mixed Use Building

1. Lot

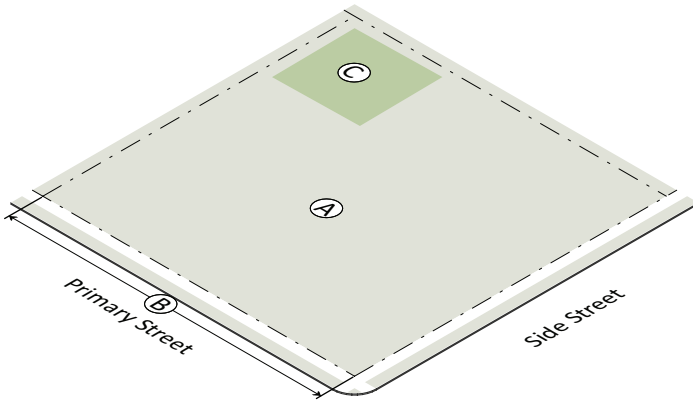

2. Placement

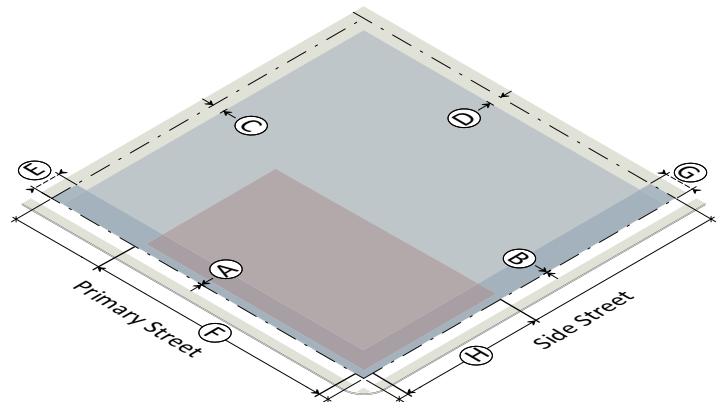

Lot Dimensions

Ⓐ Lot area (min)	5,000 SF
Ⓑ Lot width (min)	50'

Lot Parameters

Ⓒ % of outdoor amenity space (min)	10%
------------------------------------	-----

Building Setbacks

Ⓐ Primary street (min)	0'
Ⓑ Side street (min)	0'
Ⓒ Side interior (min)	0' or 5'
Ⓒ Side interior, abutting protected district, RA-3 or RD-2 (min)	10'
Ⓓ Rear (min)	0' or 5'
Ⓓ Rear, abutting protected district, RA-3 or RD-2 (min)	20'
Ⓓ Abutting alley (min)	5'

Build-to Zone (BTZ)

Ⓔ Primary street (min/max)	0' to 10'
Ⓕ Building in primary street BTZ (min % of lot width)	70%
Ⓖ Side street (min/max)	0' to 10'
Ⓗ Building in side street BTZ (min % of lot width)	35%

Parking Location

Ⓘ On-site parking not allowed between the building and the street	
---	--

3. Height

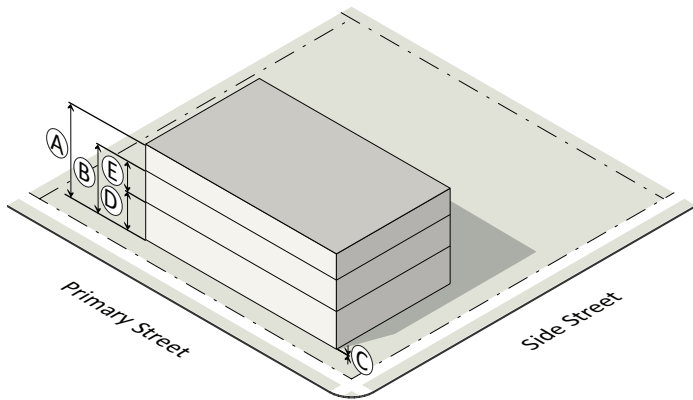

4. Activation

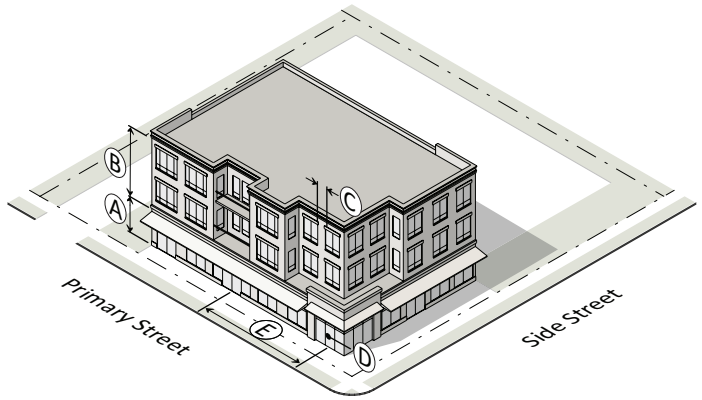

Building Height

Ⓐ Building height (max)	
MX-3	3 stories/45'
MX-4 , EM-4	4 stories/55'
MX-5	5 stories/67'
Reduced height may be required when abutting a protected district (see Sec. 3.17.O)	

Ⓑ Building height (min)	2 stories
-------------------------	-----------

Story Height

Ⓒ Ground floor elevation	0'
Ⓓ Ground story height, floor to ceiling (min)	13'
Ⓔ Upper story height, floor to ceiling (min)	9'

Transparency

Ⓐ Ground story (min)	60%
Ⓑ Upper story (min)	20%
Ⓒ Blank wall area (max)	30'
The street-fronting, street-level window pane surface area must allow views into the ground story use for a depth of at least 8 feet.	

Pedestrian Access

Ⓓ Entrance facing primary street	Required
Ⓔ Entrance spacing along primary street (max)	75'

Permitted Building Elements

Porch	No
Stoop	No
Balcony	Yes
Gallery	Yes
Awning/Canopy	Yes
Forecourt	Yes

Sec. 3.4. Shopfront Building

1. Lot

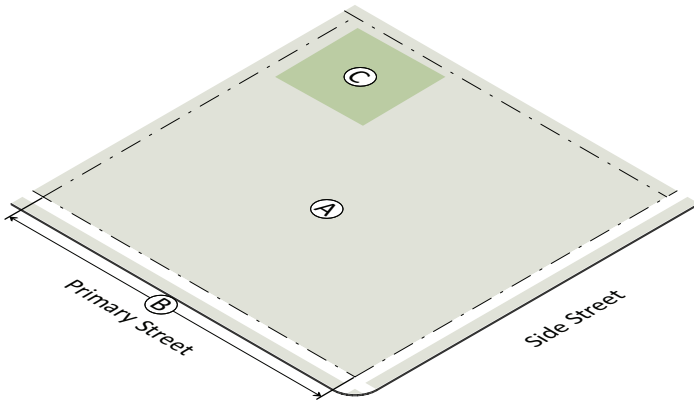

2. Placement

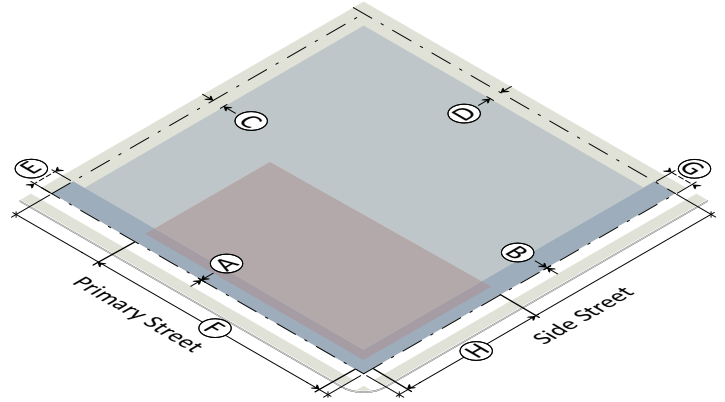

Lot Dimensions

Ⓐ Lot area (min)	5,000 SF
Ⓑ Lot width (min)	50'

Lot Parameters

Ⓒ % of outdoor amenity space (min)	10%
------------------------------------	-----

Building Setbacks

Ⓐ Primary street (min)	0'
Ⓑ Side street (min)	0'
Ⓒ Side interior (min)	0' or 5'
Ⓒ Side interior, abutting protected district, RA-3 or RD-2 (min)	10'
Ⓓ Rear (min)	0' or 5'
Ⓓ Rear, abutting protected district, RA-3 or RD-2 (min)	20'
Ⓓ Abutting alley (min)	5'

Build-to Zone (BTZ)

Ⓔ Primary street (min/max)	0' to 10'
Ⓕ Building in primary street BTZ (min % of lot width)	70%
Ⓖ Side street (min/max)	0' to 10'
Ⓗ Building in side street BTZ (min % of lot width)	35%

Parking Location

Ⓘ On-site parking not allowed between the building and the street	
---	--

3. Height

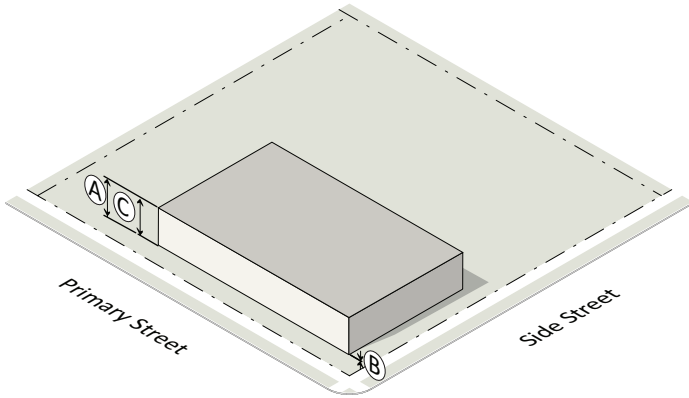

Building Height	
Ⓐ Building height (max)	1 story/25'
Story Height	
Ⓑ Ground floor elevation	0'
Ⓒ Ground story height, floor to ceiling (min)	13'

4. Activation

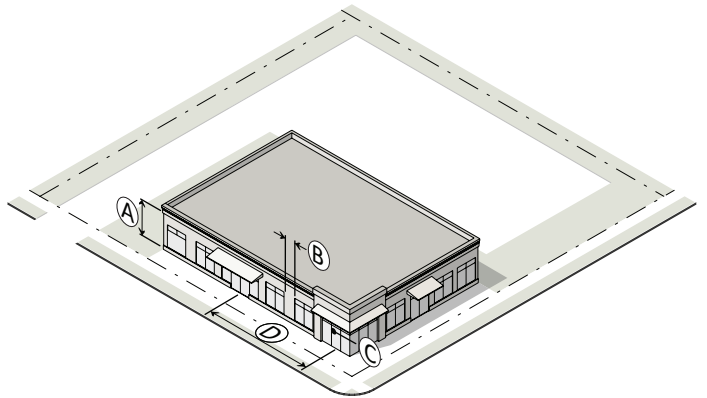

Transparency	
Ⓐ Ground story (min)	60%
Ⓑ Blank wall area (max)	30'
The street-fronting, street-level window pane surface area must allow views into the ground story use for a depth of at least 8 feet.	

Pedestrian Access	
Ⓒ Entrance facing primary street	Required
Ⓓ Entrance spacing along primary street (max)	75'

Allowed Building Elements	
Porch	No
Stoop	No
Balcony	No
Gallery	Yes
Awning/Canopy	Yes
Forecourt	Yes

Sec. 3.5. General Building

1. Lot

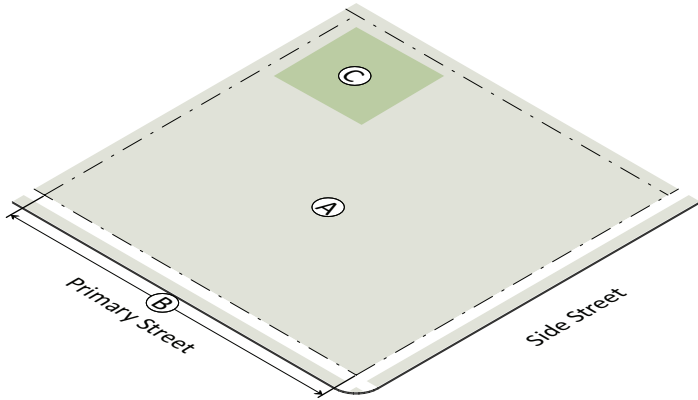

Lot Dimensions

Ⓐ Lot area (min)	5,000 SF
Ⓑ Lot width (min)	50'

Lot Parameters

Ⓒ % of outdoor amenity space (min)	10%
------------------------------------	-----

2. Placement

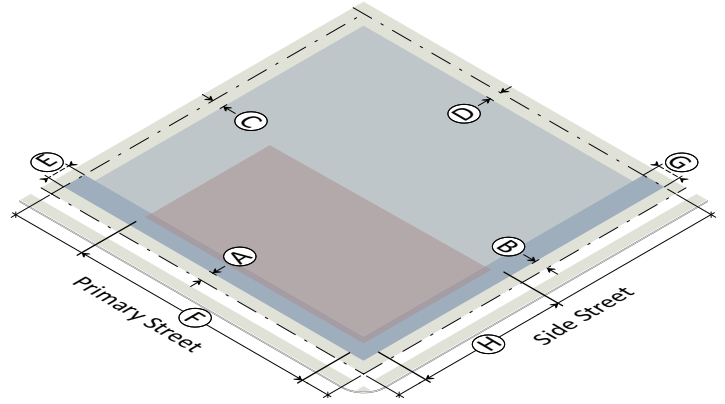

Building Setbacks

Ⓐ Primary street (min)	5'
Ⓑ Side street (min)	5'
Ⓒ Side interior (min)	0' or 5'
Ⓒ Side interior, abutting protected district, RA-3 or RD-2 (min)	10'
Ⓓ Rear (min)	0' or 5'
Ⓓ Rear, abutting protected district, RA-3 or RD-2 (min)	20'
Ⓓ Abutting alley (min)	5'

Build-to Zone (BTZ)

Ⓔ Primary street (min/max)	5' to 20'
Ⓕ Building in primary street BTZ (min % of lot width)	70%
Ⓖ Side street (min/max)	5' to 20'
Ⓗ Building in side street BTZ (min % of lot width)	35%

Parking Location

Ⓘ On-site parking not allowed between the building and the street	
---	--

3. Height

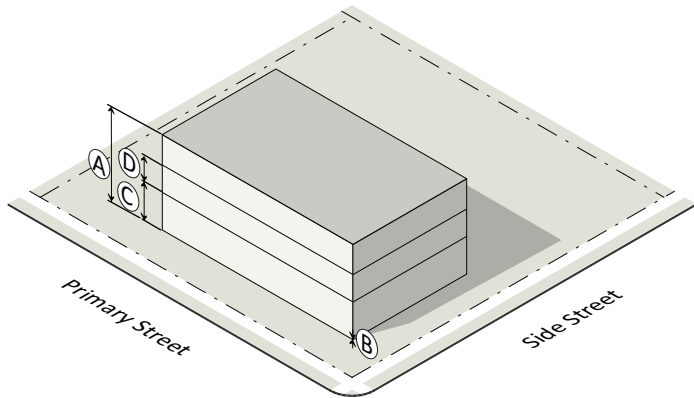

4. Activation

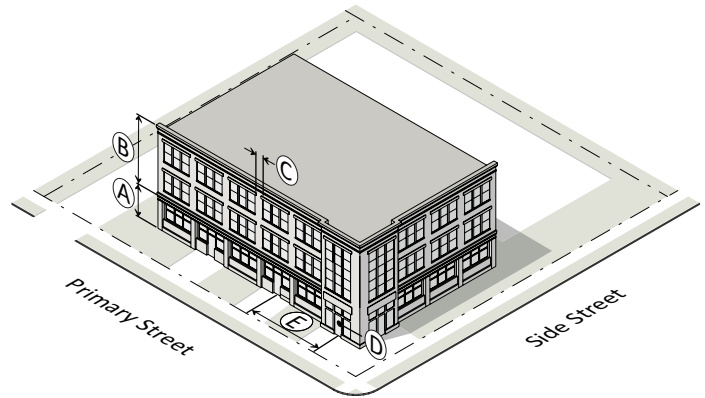

Building Height

Ⓐ Building height (max)	
EM-2	2 stories/35'
MX-3, EM-3	3 stories/45'
MX-4, EM-4	4 stories/60'
MX-5	5 stories/75'
EM-6	6 stories/90'
EM-9	9 stories/135'

Reduced height may be required when abutting a protected district (see Sec. 3.17.O)

Story Height

Ⓑ Ground floor elevation	0'
Ⓒ Ground story height, floor to ceiling (min)	11'
Ⓓ Upper story height, floor to ceiling (min)	9'

Transparency

Ⓐ Ground story (min)	40%
Ⓑ Upper story (min)	20%
Ⓒ Blank wall area (max)	35'

Pedestrian Access

Ⓓ Entrance facing primary street	Required
Ⓔ Entrance spacing along primary street (max)	100'

Allowed Building Elements

Porch	No
Stoop	No
Balcony	Yes
Gallery	Yes
Awning/Canopy	Yes
Forecourt	Yes

Sec. 3.6. Civic Building

1. Lot

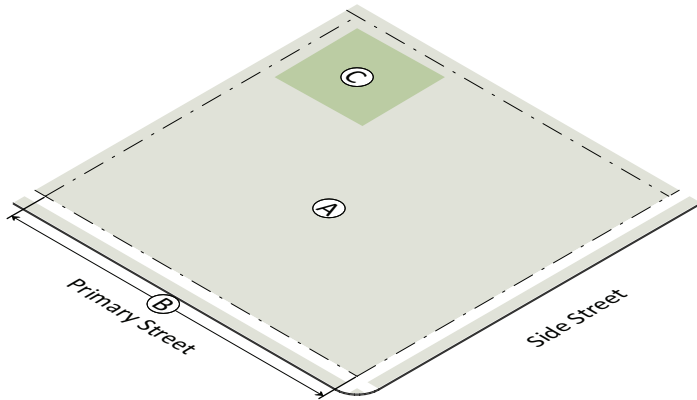

Lot Dimensions

Ⓐ Lot area (min)	5,000 SF
Ⓑ Lot width (min)	50'

Lot Parameters

Ⓒ % of outdoor amenity space (min)	10%
------------------------------------	-----

2. Placement

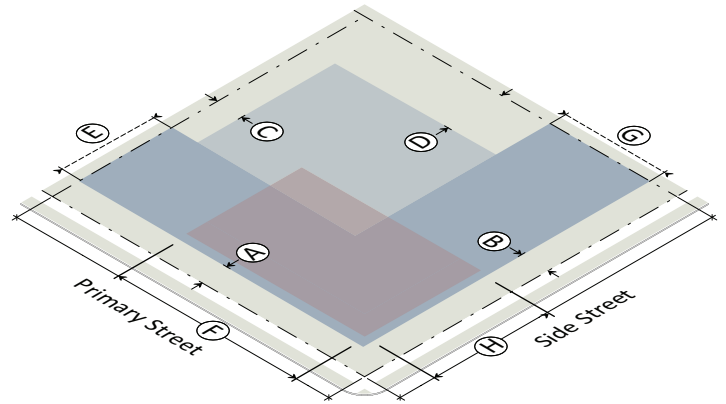

Building Setbacks

Ⓐ Primary street (min)	10'
Ⓑ Side street (min)	10'
Ⓒ Side interior (min)	10'
Ⓓ Rear (min)	20'
Ⓔ Abutting alley (min)	5'

Build-to Zone (BTZ)

Ⓔ Primary street (min/max)	10' to 40'
Ⓕ Building in primary street BTZ (min % of lot width)	40%
Ⓖ Side street (min/max)	10' to 40'
Ⓗ Building in side street BTZ (min % of lot width)	20%

Parking Location

Ⓘ On-site parking not allowed between the building and the street	
---	--

3. Height

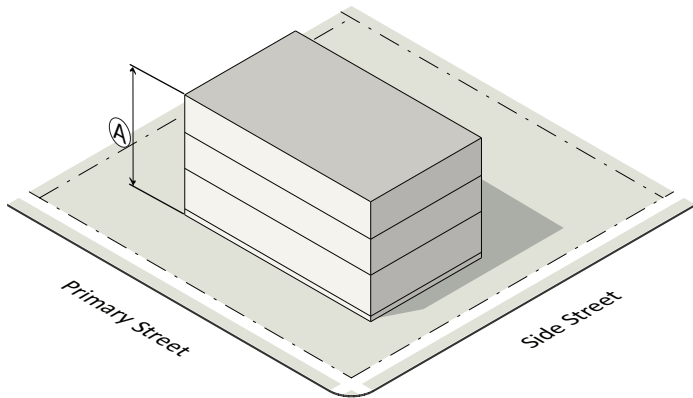

4. Activation

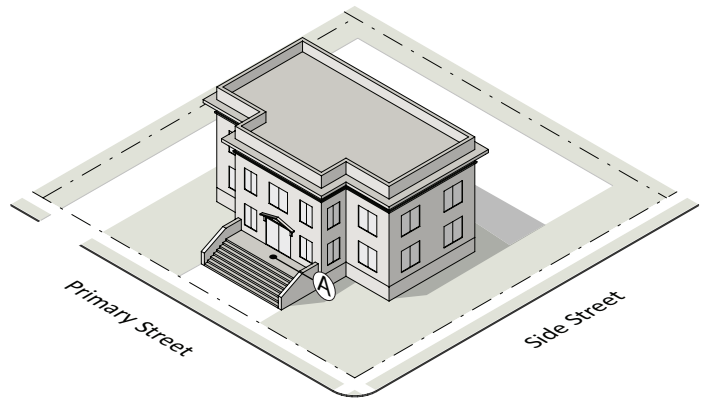

Building Height

Ⓐ Building height (max)	
EM-2	2 stories/35'
RA-3, MX-3, EM-3	3 stories/45'
MX-4, MX-5, EM-4, EM-6, EM-9	4 stories/55'
Reduced height may be required when abutting a protected district (see Sec. 3.17.O)	

Pedestrian Access

Ⓐ Entrance facing primary street	Required
----------------------------------	----------

Allowed Building Elements

Porch	Yes
Stoop	Yes
Balcony	Yes
Gallery	Yes
Awning/Canopy	Yes
Forecourt	Yes

Uses Allowed in a Civic Building Type

Only the following uses are allowed in a civic building type (see Sec. 4.4. Permitted Use Table):

- College, university.
- Museum, library.
- Place of worship,
- School (K-12).

Sec. 3.7. Apartment Building

1. Lot

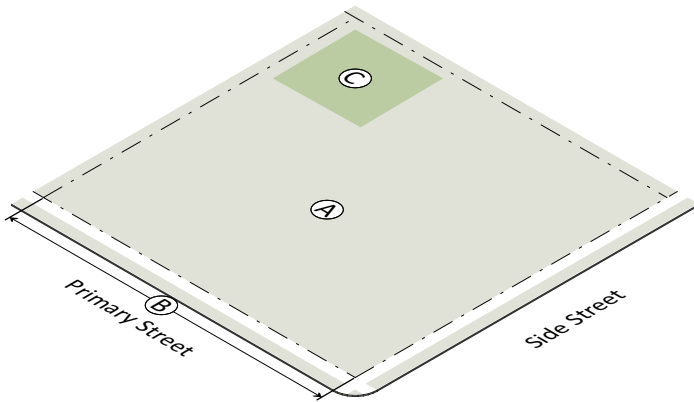

Lot Dimensions

Ⓐ Lot area (min)	12,500 SF
Ⓑ Lot width (min)	100'

Lot Parameters

Ⓒ % of outdoor amenity space (min)	10%
------------------------------------	-----

2. Placement

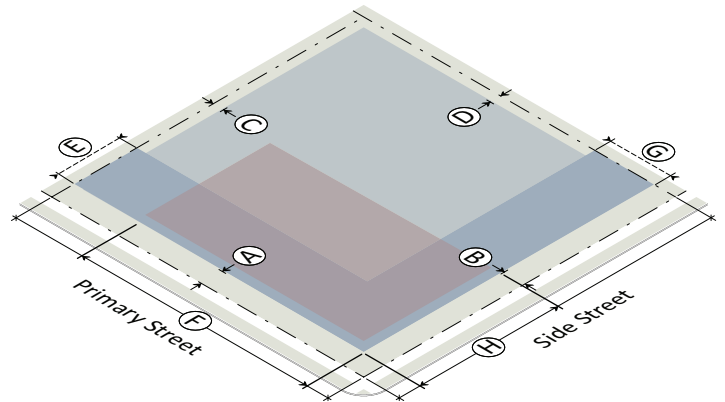

Building Setbacks

Ⓐ Primary street (min)	10'
Ⓑ Side street (min)	10'
Ⓒ Side interior (min)	0' or 5'
Ⓒ Side interior, abutting protected district, RA-3 or RD-2 (min)	10'
Ⓓ Rear (min)	0' or 5'
Ⓓ Rear, abutting protected district, RA-3 or RD-2 (min)	20'
Ⓓ Abutting alley (min)	5'

Build-to Zone (BTZ)

Ⓔ Primary street (min/max)	10' to 20'
Ⓕ Building in primary street BTZ (min % of lot width)	70%
Ⓖ Side street (min/max)	10' to 20'
Ⓗ Building in side street BTZ (min % of lot width)	35%

Parking Location

Ⓘ On-site parking not allowed between the building and the street	
---	--

3. Height

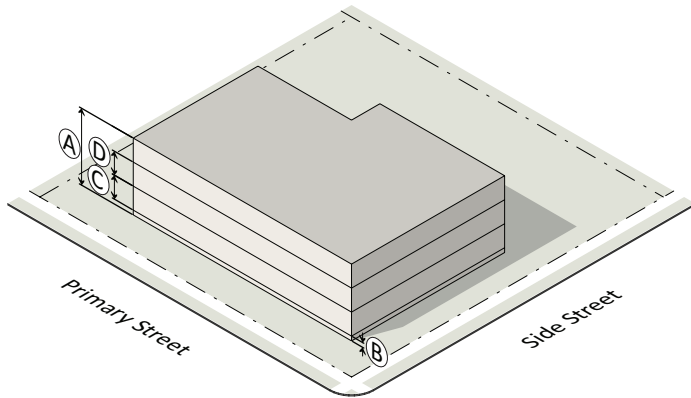

4. Activation

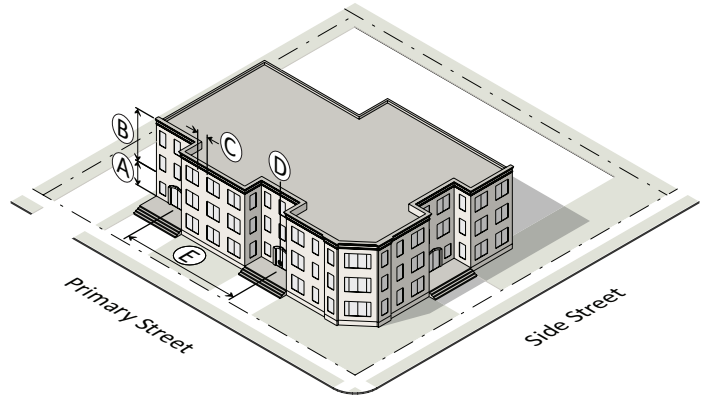

Building Height

Ⓐ Building height (max)	
EM-2	2 stories/35'
MX-3, EM-3	3 stories/45'
MX-4, MX-5	4 stories/55'
Reduced height may be required when abutting a protected district (see Sec. 3.17.O)	

Story Height

Ⓑ Ground floor elevation (min)	2'
Ⓒ Ground story height, floor to ceiling (min)	10'
Ⓓ Upper story height, floor to ceiling (min)	9'

Transparency

Ⓐ Ground story (min)	20%
Ⓑ Upper story (min)	20%
Ⓒ Blank wall area (max)	35'

Pedestrian Access

Ⓓ Entrance facing primary street	Required
Ⓔ Entrance spacing along primary street (max)	100'

Building Elements

Porch	Allowed
Stoop	Allowed
Balcony	Allowed
Gallery	Not allowed
Awning/Canopy	Allowed
Forecourt	Allowed

Sec. 3.8. Apartment Court

1. Lot

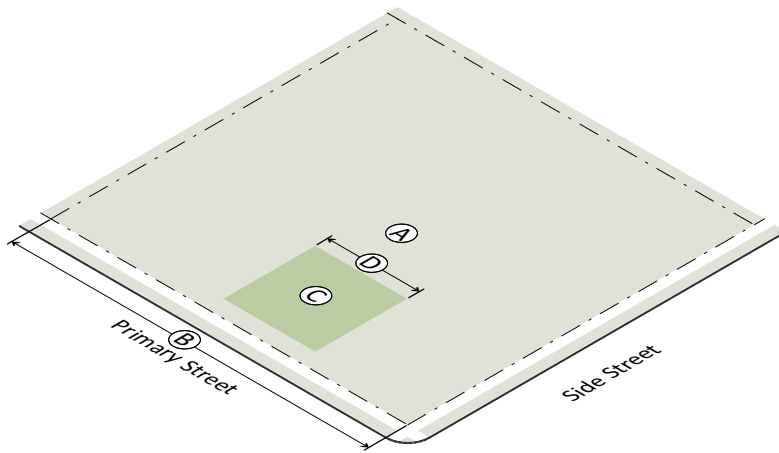

2. Placement

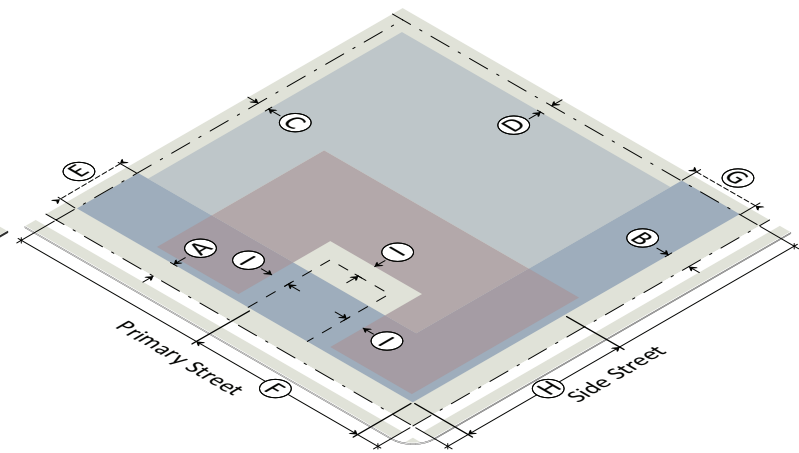

Lot Dimensions

Ⓐ Lot area (min)	30,000 SF
Ⓑ Lot width (min)	150'

Courtyard Dimensions

Ⓒ Area (min)	2,000 SF
Ⓒ % of outdoor amenity space (min)	10%
Ⓓ Width (min)	45'

Area devoted to courtyard counted toward outdoor amenity space.

Building Setbacks

Ⓐ Primary street (min)	10'
Ⓑ Side street (min)	10'
Ⓒ Side interior (min)	0' or 5'
Ⓒ Side interior, abutting protected district, RA-3 or RD-2 (min)	10'
Ⓓ Rear (min)	0' or 5'
Ⓓ Rear, abutting protected district, RA-3 or RD-2 (min)	20'
Ⓓ Abutting alley (min)	5'

Build-to Zone (BTZ)

Ⓔ Primary street (min/max)	10' to 20'
Ⓕ Building in primary street BTZ (min % of lot width)	40%
Ⓖ Side street (min/max)	10' to 20'
Ⓖ Building in side street BTZ (min % of lot width)	40%

Courtyard Encroachment

Ⓚ Porch including steps (max)	8'
Ⓚ Balcony (max)	6'

Parking Location

Ⓜ On-site parking not allowed between the building and the street	
---	--

3. Height

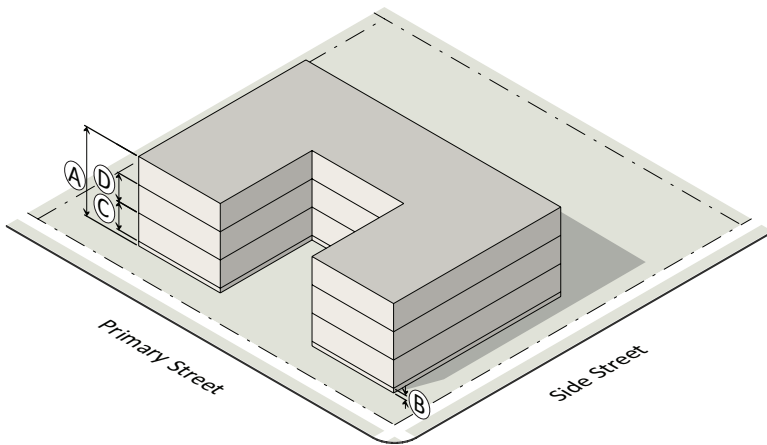

4. Activation

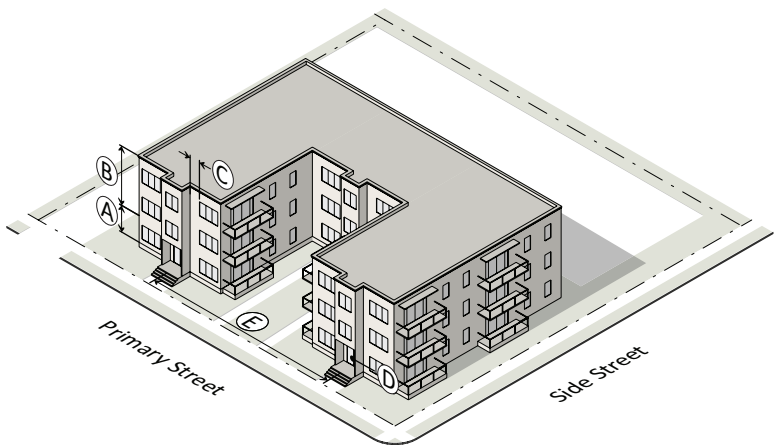

Building Height

(A) Building height (max)	
EM-2	2 stories/35'
MX-3, EM-3	3 stories/45'
MX-4, MX-5	4 stories/55'
Reduced height may be required when abutting a protected district (see Sec. 3.17.O)	

Story Height

(B) Ground floor elevation (min)	2'
(C) Ground story height, floor to ceiling (min)	10'
(D) Upper story height, floor to ceiling (min)	9'

Transparency

(A) Ground story (min)	20%
(B) Upper story (min)	20%
(C) Blank wall area (max)	35'

Pedestrian Access

(D) Entrance facing primary street	Required
(E) Entrance spacing along primary street (max)	100'

Building Elements

Porch	Allowed
Stoop	Allowed
Balcony	Allowed
Gallery	Not allowed
Awning/Canopy	Allowed
Forecourt	Not allowed

Sec. 3.9. Garden Apartment

1. Lot

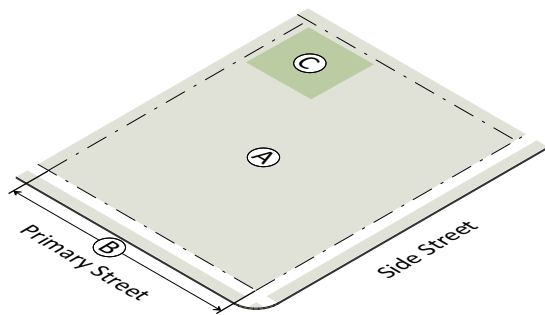

Lot Dimensions

Ⓐ Lot area (min)	12,500 SF
Ⓑ Lot width (min)	100'

Lot Parameters

Ⓒ % of outdoor amenity space (min)	10%
Ⓓ Dwelling units per building (max)	12

2. Placement

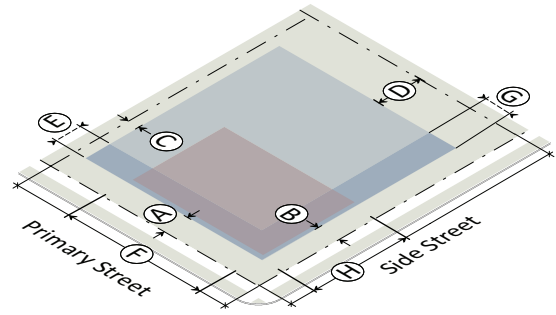

Building Setbacks

Ⓐ Primary street (min)	10'
Ⓑ Side street (min)	10'
Ⓒ Side interior (min)	5'
Ⓒ Side interior, abutting protected district or RD-2 (min)	10'
Ⓓ Rear (min)	20'
Ⓓ Abutting alley (min)	5'

Build-to Zone (BTZ)

Ⓔ Primary street (min/max)	10' to 20'
Ⓕ Building in primary street BTZ (min % of lot width)	70%
Ⓖ Side street (min/max)	10' to 20'
Ⓗ Building in side street BTZ (min % of lot width)	35%

Parking Location

Ⓘ On-site parking not allowed between the building and the street	
---	--

3. Height

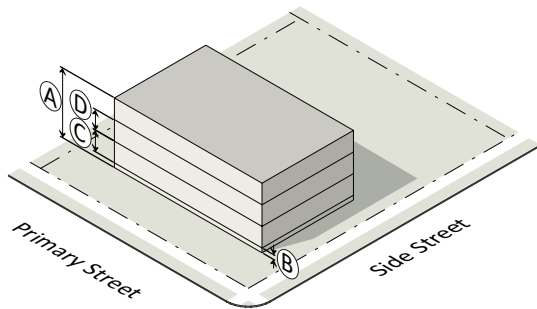

4. Activation

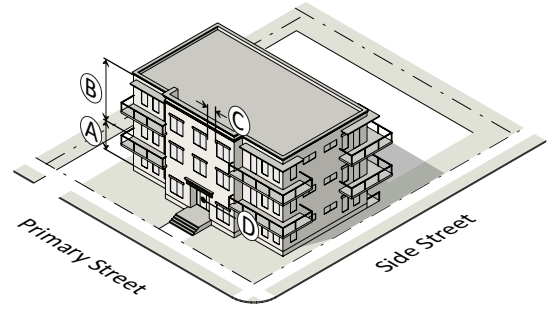

Building Height

Ⓐ Building height (max)	
EM-2	2 stories/35'
RA-3, EM-3, MX-3, MX-4, MX-5	3 stories/45'
Reduced height may be required when abutting a protected district (see Sec. 3.17.O)	

Story Height

Ⓑ Ground floor elevation (min)	2'
Ⓒ Ground story height, floor to ceiling (min)	10'
Ⓓ Upper story height, floor to ceiling (min)	9'

Transparency

Ⓐ Ground story (min)	20%
Ⓑ Upper story (min)	20%
Ⓒ Blank wall area (max)	35'

Pedestrian Access

Ⓓ Entrance facing primary street	Required
Ⓔ Entrance spacing along primary street (max)	100'

Building Elements

Porch	Allowed
Stoop	Allowed
Balcony	Allowed
Gallery	Not allowed
Awning/Canopy	Allowed
Forecourt	Allowed

Sec. 3.10. Stacked Flat

1. Lot

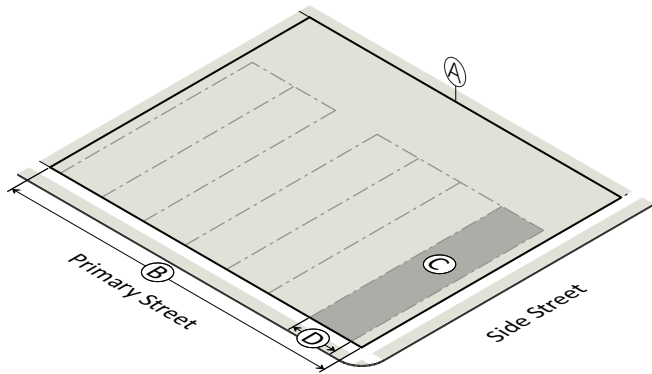

2. Placement

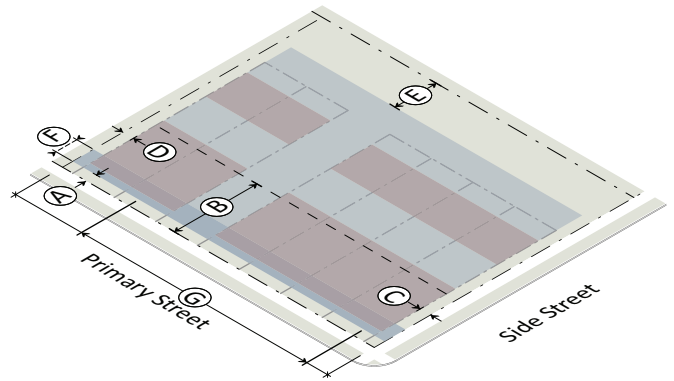

Site Dimensions

Ⓐ Site area (min)	12,500 SF
Ⓑ Site width (min)	100'

Lot Dimensions

Ⓒ Lot area (min)	1,300 SF
Ⓓ Unit width (min/max)	20' to 30'

Building Setbacks

Ⓐ Primary street - principal buildings (min)	5'
Ⓑ Primary street - accessory structures (min)	40'
Ⓒ Side street (min)	5'
Ⓓ Side interior, end unit only (min)	5'
Ⓓ Side interior, abutting protected district, RA-3 or RD-2 (min)	10'
Ⓔ Rear (min)	20'
Ⓕ Abutting alley	4' or 20' min

Build-to Zone (BTZ)

Ⓕ Primary street (min/max)	5' to 10'
Ⓖ Building in primary street BTZ (min % of lot width)	70%

Parking Location

Ⓗ On-site parking not allowed between the building and the street	
---	--

3. Height

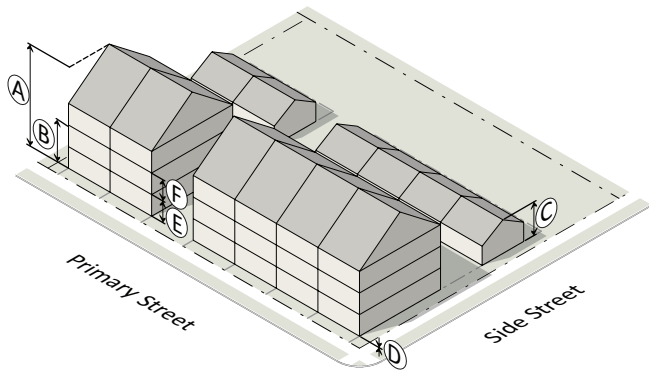

4. Activation

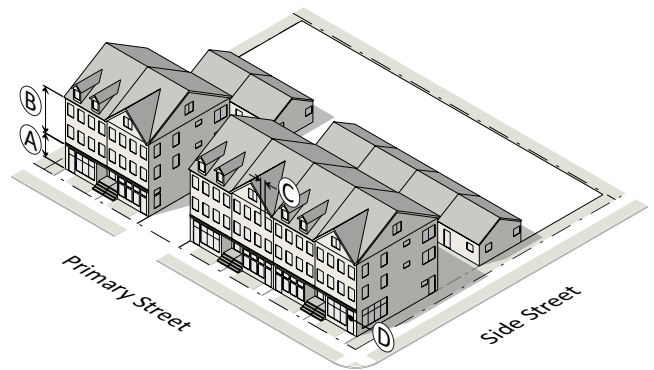

Building Height

Ⓐ Principal building (max)	
EM-2	2 stories/35'
EM-3, MX-3, MX-4, MX-5	3 stories/45'
Reduced height may be required when abutting a protected district (see Sec. 3.17.O)	
Ⓑ Principal building (min)	2 stories
Ⓒ Accessory structure (max)	24'

Story Height

Ⓓ Ground floor elevation	0'
Ⓔ Ground story height, floor to ceiling (min)	12'
Ⓕ Upper story height, floor to ceiling (min)	9'

Transparency

Ⓐ Ground story (min)	40%
Ⓑ Upper story (min)	20%
Ⓒ Blank wall area (max)	35'

Pedestrian Access

Ⓓ Entrance facing primary street (each ground floor unit)	Required
---	----------

Building Elements

Porch	Not allowed
Stoop	Allowed
Balcony	Allowed
Gallery	Not allowed
Awning/Canopy	Allowed
Forecourt	Not allowed

Sec. 3.11. Townhouse

1. Lot

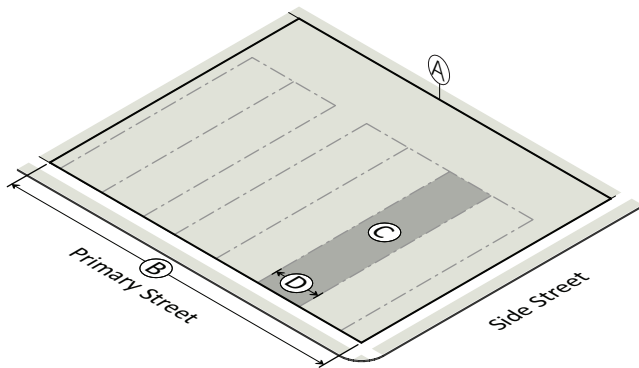

2. Placement

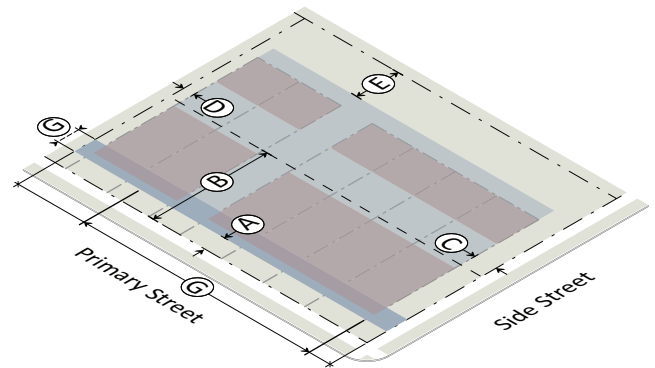

Site Dimensions

Ⓐ Site area (min)	10,000 SF
Ⓑ Site width (min)	100'

Lot Dimensions

Ⓒ Lot area (min)	1,300 sf
Ⓓ Dwelling unit width (min/max)	20' to 30'
Ⓔ RA-3: Dwelling units per building (max)	6

Building Setbacks

Ⓐ Primary street - principal buildings (min)	5'
Ⓑ Primary street - accessory structures (min)	40'
Ⓒ Side street (min)	10'
Ⓓ Side interior, end unit only (min)	5'
Ⓓ Side interior, abutting protected district or RD-2 (min)	10'
Ⓔ Rear (min)	20'
Ⓔ Abutting alley	4' or 20' min

Build-to Zone (BTZ)

Ⓕ Primary street (min/max)	5' to 15'
Ⓕ Building in primary street BTZ (min % of lot width)	70%

Parking Location

1. On-site parking is not allowed between the building and the street.
2. Parking must be placed entirely to the rear of the townhouse and be rear-accessed.
3. Front-loaded townhouses are not allowed.
4. Garage doors must face the rear alley.

3. Height

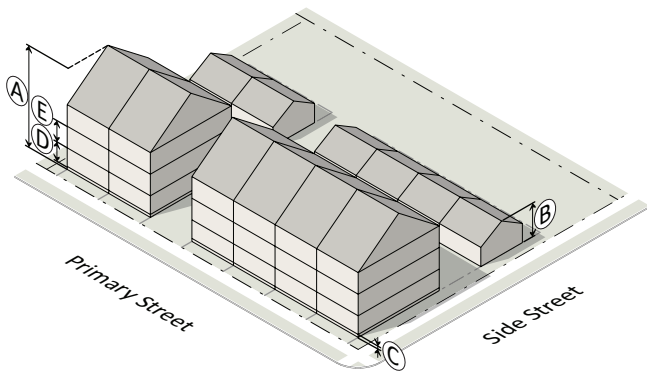

4. Activation

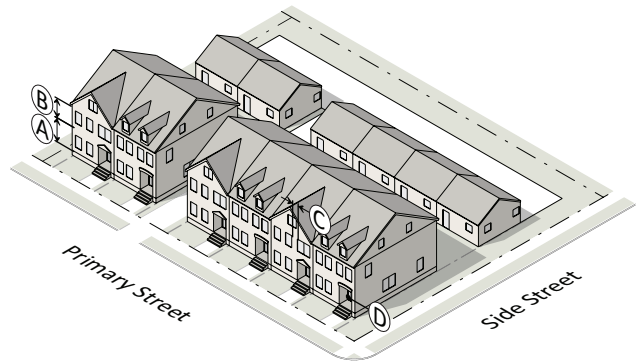

Building Height

Ⓐ Principal building (max)	
EM-2	2 stories/35'
RA-3, EM-3, MX-3, MX-4, MX-5	3 stories/45'
Reduced height may be required when abutting a protected district (see Sec. 3.17.O)	
Ⓑ Accessory structure (max)	24'

Story Height

Ⓒ Ground floor elevation (min)	2'
Ⓓ Ground story height, floor to ceiling (min)	10'
Ⓔ Upper story height, floor to ceiling (min)	9'

Transparency

Ⓐ Ground story (min)	20%
Ⓑ Upper story (min)	20%
Ⓒ Blank wall area (max)	35'

Pedestrian Access

Ⓓ Entrance facing primary street (each ground floor unit)	Required
---	----------

Building Elements

Porch	Allowed
Stoop	Allowed
Balcony	Allowed
Gallery	Not allowed
Awning/Canopy	Not allowed
Forecourt	Not allowed

Sec. 3.12. Cottage Court

1. Lot

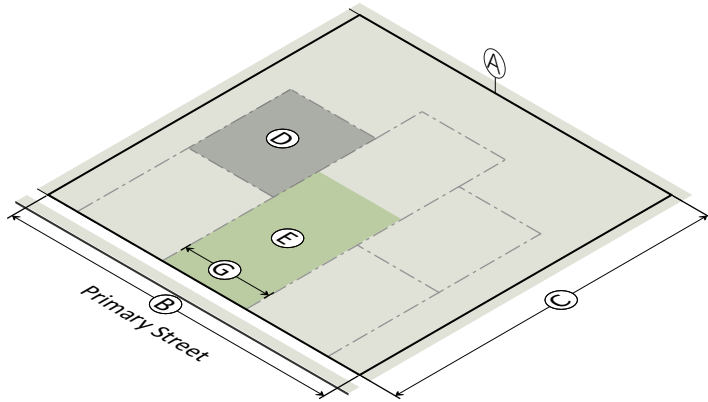

2. Placement

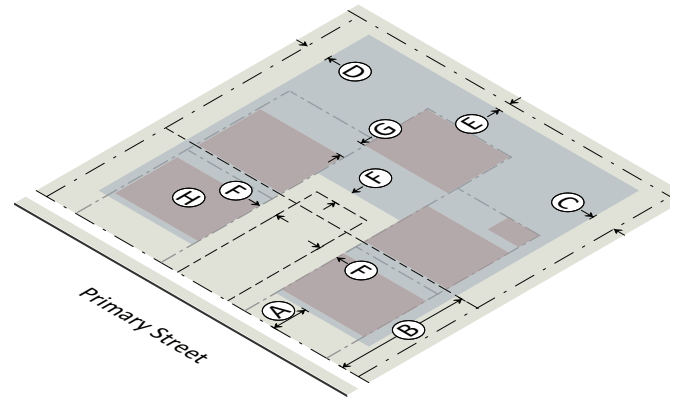

Site Dimensions

Ⓐ Site area (min)	22,500 SF
Site area per detached house (min)	4,500 SF
Detached houses per site (max)	9
Ⓑ Site width (min)	150'
Ⓒ Site depth (min)	150'

Lot Dimensions

Ⓓ Lot area (min)	1,200 SF
------------------	----------

Courtyard

Ⓔ Area (min)	3,000 SF
Ⓕ Courtyard area per detached house (min)	600 SF
Ⓖ Width (min)	40'

A cottage lot abutting a courtyard that meets the above standards meets the platting requirements for frontage on an improved public street.

Building Setbacks

Ⓐ Primary street - principal buildings (min)	15'
Ⓑ Primary street - accessory structures (min)	30'
Ⓒ Side street (min)	10'
Ⓓ Side interior (min)	5'
Ⓔ Rear (min)	10'
Ⓕ Abutting alley	4' or 20' min
Ⓖ Abutting courtyard	0'

Placement Limitations

Ⓖ Building separation (min)	10'
Ⓗ Principal building footprint (max)	1,200 SF

Parking Location

Ⓘ On-site parking not allowed between the building and the street	
---	--

3. Height

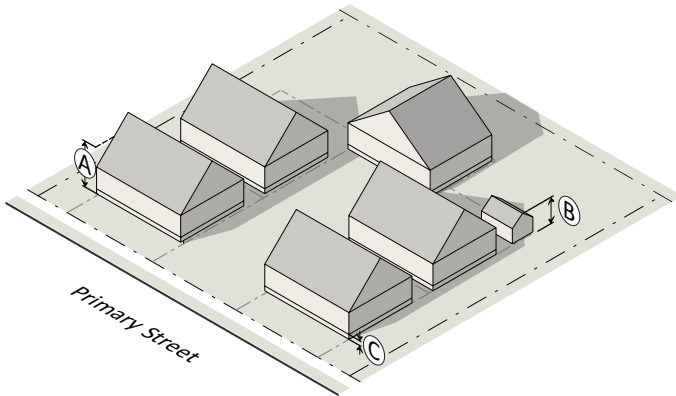

4. Activation

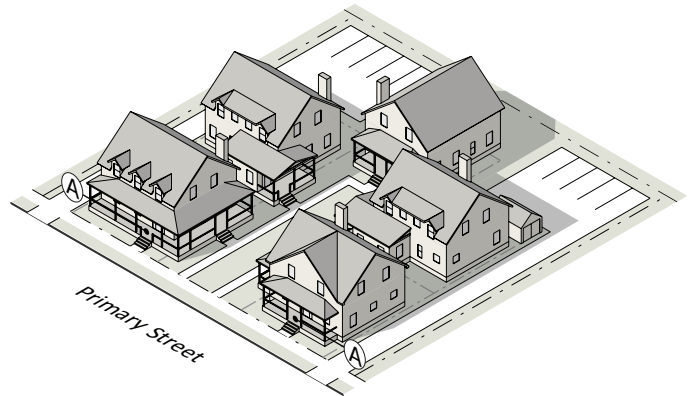

Building Height

Ⓐ Principal buildings (max)	
RD-2	1 story/25'
RA-3	2 stories/40'
Ⓑ Accessory structures (max)	18'

Story Height

Ⓒ Ground floor elevation (min)	2'
--------------------------------	----

Pedestrian Access

Ⓐ Entrance facing primary street	Required for end units
----------------------------------	------------------------

Building Elements

Porch	Allowed
Stoop	Allowed
Balcony	Allowed
Gallery	Not allowed
Awning/Canopy	Not allowed
Forecourt	Not allowed

Sec. 3.13. Detached House

1. Lot

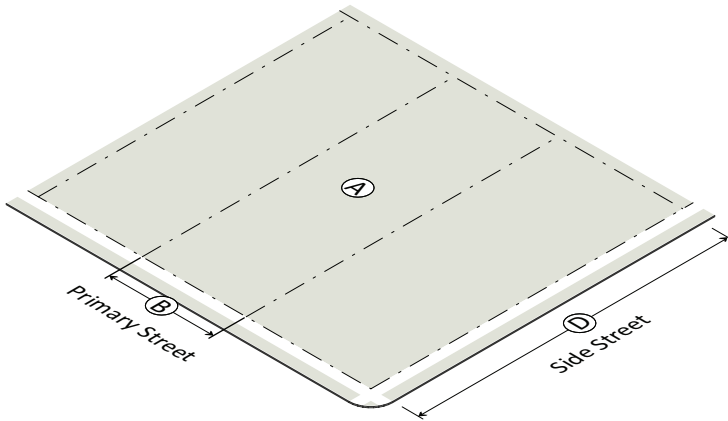

2. Placement

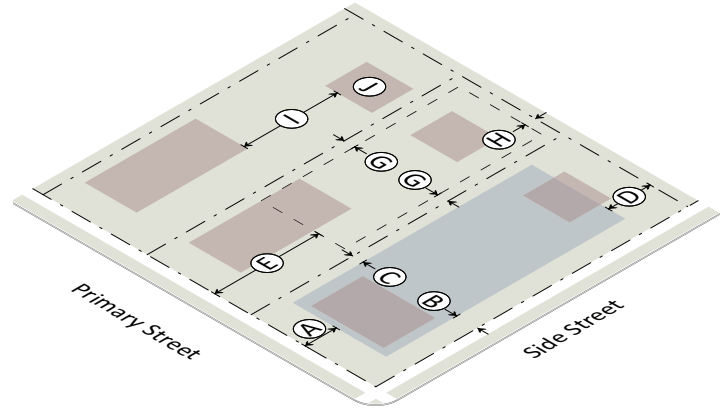

Lot Dimensions

Ⓐ Lot area (min)	7,500 SF
Ⓐ Lot area - rear loaded (min)	5,000 SF
Ⓑ Lot width (min)	50'
Ⓑ Lot width - rear loaded (min)	40'
Ⓒ Dwelling units per lot (max)	1

Additional Requirements with Carriage House

Ⓓ Lot depth (min)	120'
Ⓔ Additional detached dwelling unit (max)	1
Ⓕ Additional on-site parking (min)	1 space

Principal Building Setbacks

Ⓐ Primary street (min)	15'
Ⓑ Side street (min)	10'
Ⓒ Side interior (min)	5'
Ⓓ Rear (min)	20'
Ⓓ Abutting alley	4' or 20' min

Accessory Structure/Carriage House Setbacks

Ⓔ Primary street (min)	50'
Ⓕ Side street (min)	10'
Ⓖ Side interior (min)	5'
Ⓗ Rear (min)	5'
Ⓗ Abutting alley	4' or 20' min

Accessory Structure/Carriage House Limitations

Ⓘ Building separation (min)	10'
Ⓙ Conditioned space (max)	600 sf

Parking Location

Ⓚ The combined parking and driveway area cannot be more than 40% of the area between the front building facade and the front property line. Any parking in the front setback must have sufficient depth so that parked cars do not encroach on the adjacent sidewalk.

3. Height

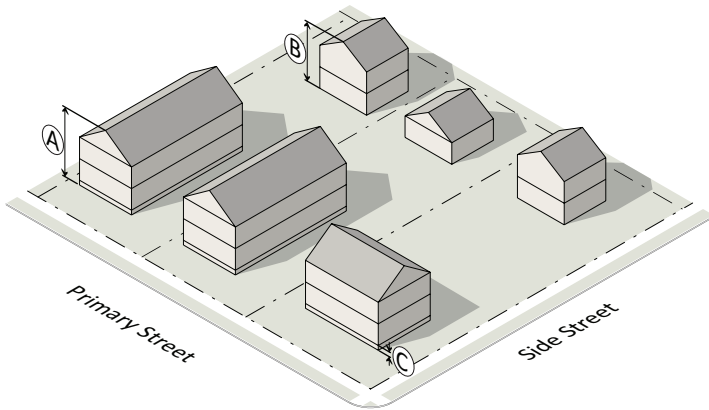

4. Activation

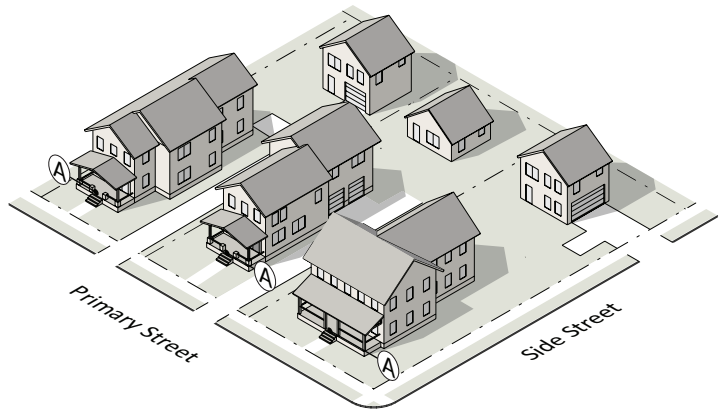

Building Height

Ⓐ Principal building (max)	
RD-2	2 stories/35'
RA-3	2 stories/40'
Ⓑ Accessory structure (max)	24'

Story Height

Ⓒ Ground floor elevation (min)	2'
--------------------------------	----

Pedestrian Access

Ⓐ Entrance facing primary street	Required
----------------------------------	----------

Building Elements

Porch	Allowed
Stoop	Allowed
Balcony	Allowed
Gallery	Not allowed
Awning/Canopy	Not allowed
Forecourt	Not allowed

Sec. 3.14. Special Rules for the OS District

1. Lot, Placement

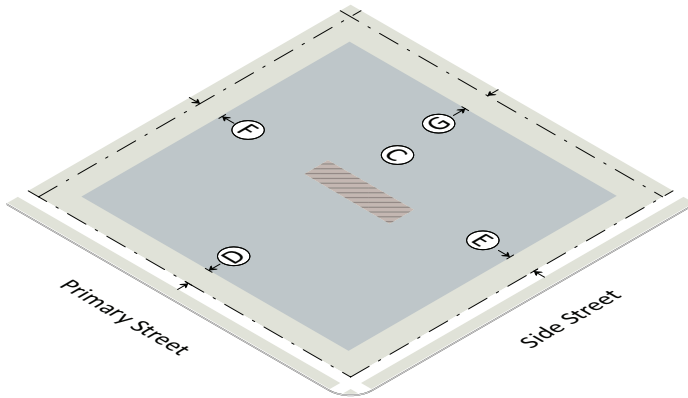

2. Height

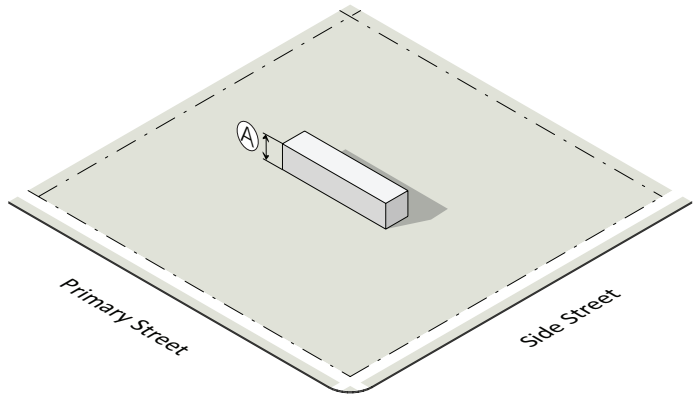

Lot Dimensions	
(A) Lot area (min)	--
(B) Lot width (min)	--
Lot Parameters	
(C) % of outdoor amenity space (min)	95%
All Building Setbacks	
(D) Primary street (min)	10'
(E) Side street (min)	10'
(F) Side interior (min)	10'
(G) Rear (min)	10'
Parking Location	
(H) No on-site parking allowed	

Building Height	
(A) Building height (max)	20'

Sec. 3.15. Special Rules for the -HS Overlay District

Where the -HS Overlay District applies, the underlying district requirements must be met except as expressly shown below.

1. Lot, Placement

2. Height

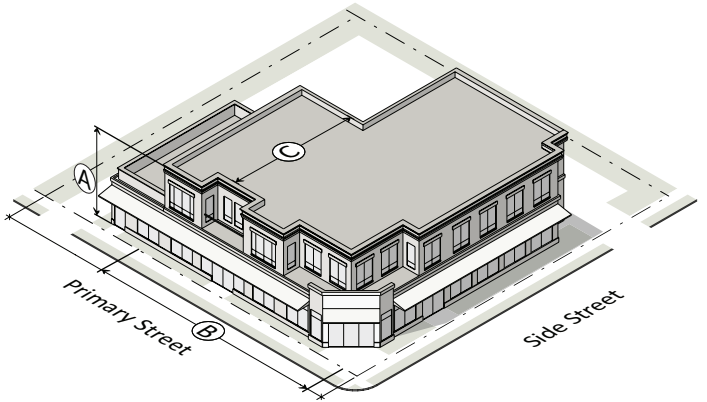
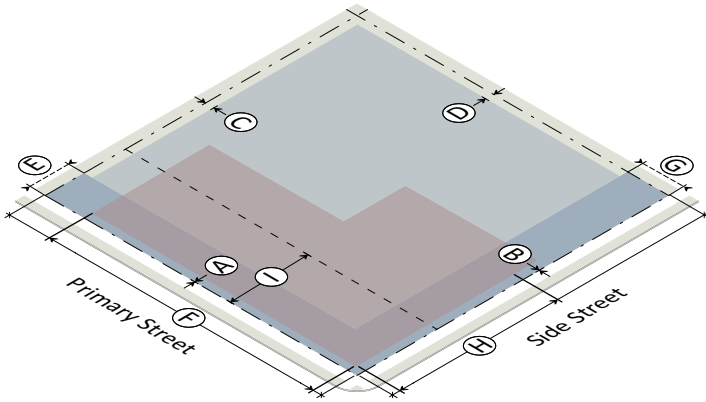

Building Setbacks	
Ⓐ Primary street (min)	0'
Ⓑ Side street (min)	0'
Ⓒ Side interior (min)	0' or 5'
Ⓓ Rear (min)	0' or 5'
Ⓔ Abutting alley (min)	5'
Build-to Zone (BTZ)	
Ⓔ Primary street (min/max)	0' to 15'
Ⓕ Building in primary street BTZ (min % of lot width)	90%
Ⓖ Side street (min/max)	0' to 15'
Ⓗ Building in side street BTZ (min % of lot width)	45%
The required BTZ may be reduced to accommodate no more than one 20-foot driveway	
Parking Setbacks	
Ⓘ All on-site surface parking spaces must be set back at least 30 feet from the Hardy Street right-of-way line	

Building Height	
Ⓐ Building height (min)	2 stories
Ⓑ Street facing facade at min height (min % of lot width)	75%
Ⓒ Depth of min height from street-facing building facade into lot (min)	50'

Sec. 3.16. Building Elements

Individual building elements are allowed or required by each specific building type (see Sec. 3.3 to Sec. 3.13).

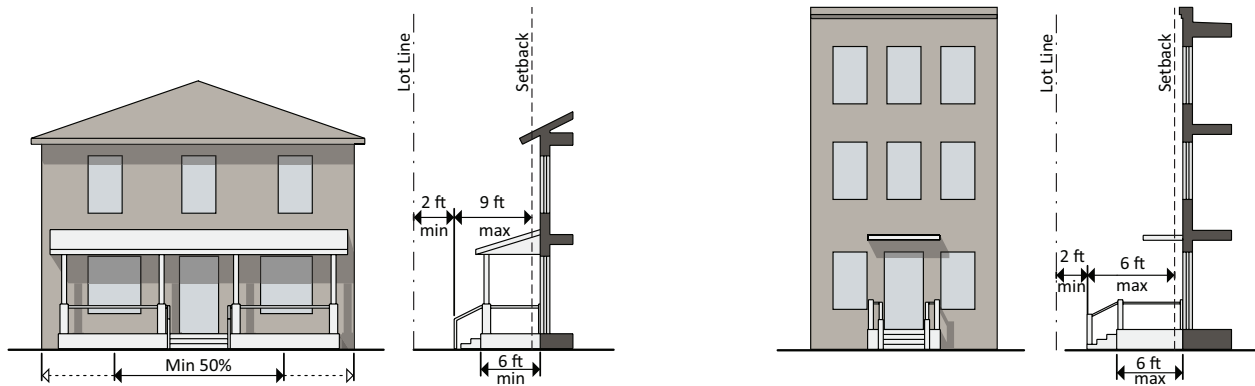

A. Porch

1. Defined

A raised structure attached to a building, forming a covered entrance to a doorway.

2. Standards

- a. A front porch must be at least 6 feet deep (not including the steps).
- b. A front porch must be contiguous, with a width not less than 50% of the building facade from which it projects.
- c. A front porch must be roofed and may be screened, but cannot be fully enclosed.
- d. A front porch may extend up to 9 feet, including the steps, into a required setback, provided that such extension is at least 2 feet from the vertical plane of any lot line.
- e. A front porch may not encroach into the public right-of-way.

B. Stoop

1. Defined

A small raised platform that serves as an entrance to a building.

2. Standards

- a. A stoop must be no more than 6 feet deep (not including the steps).
- b. A stoop may be covered but cannot be fully enclosed.
- c. A stoop may extend up to 6 feet, including the steps, into a required setback, provided that such extension is at least 2 feet from the vertical plane of any lot line.
- d. A stoop may not encroach into the public right-of-way.

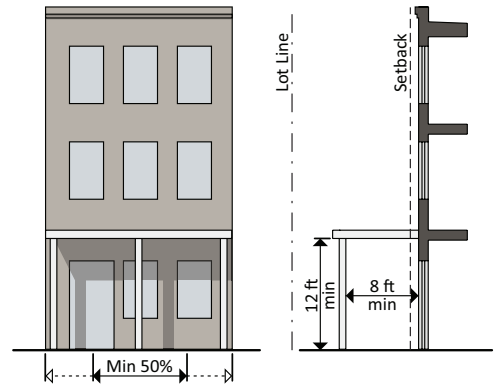
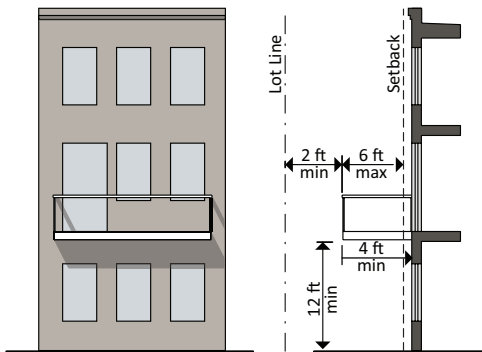

C. Balcony

1. Defined

A platform projecting from the wall of a building with a railing along its outer edge, often with access from a door or window.

2. Standards

- a. A balcony must be at least 4 feet deep and may extend up to 6 feet into a required setback, provided that such extension is at least 2 feet from the vertical plane of any lot line, with the exception of paragraph b. below.
- b. A balcony may encroach over a public sidewalk within the public right-of-way, if such encroachment is approved by the City Engineer.
- c. A balcony must have a clear height above the sidewalk of at least 12 feet.
- d. A balcony may be covered and screened, but cannot be fully enclosed.

D. Gallery

1. Defined

A covered passage extending along the outside wall of a building supported by arches or columns that is open on 3 sides.

2. Standards

- a. A gallery must have a clear depth from the support columns to the building's facade of at least 8 feet and a clear height above the sidewalk of at least 12 feet.
- b. A gallery must be contiguous and extend over at least 50% of the width of the building facade from which it projects.
- c. A gallery may extend into a required setback.
- d. A gallery may encroach over a public sidewalk within the public right-of-way, if such encroachment is approved by the City Engineer.

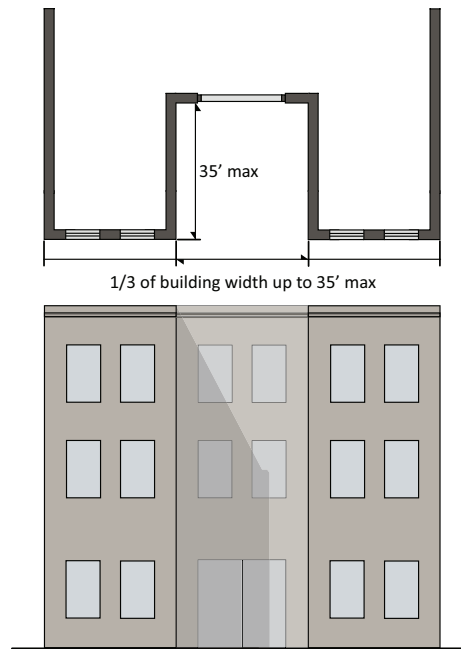
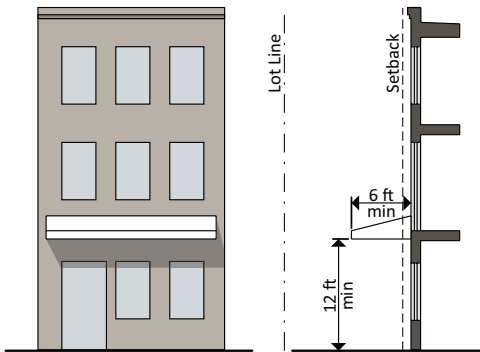

E. Awning/Canopy

1. Defined

A wall-mounted, cantilevered structure providing shade and cover from the weather for a sidewalk.

2. Standards

- a. An awning/canopy must be a minimum of 12 feet clear height above the sidewalk and must have a minimum depth of 6 feet.
- b. An awning/canopy may extend into a required setback.
- c. An awning/canopy may encroach over a public sidewalk within the public right-of-way, if such encroachment is approved by the City Engineer.

F. Forecourt

1. Defined

An open area at grade or within 30 inches of grade that serves as an open space, plaza or outdoor dining area.

2. Standards

- a. A forecourt must be no more than 1/3 of the width of the building face and in no case wider than 35 feet in width.
- b. A forecourt may be no more than 35 feet in depth.
- c. A maximum of one forecourt is permitted per lot.
- d. A forecourt meeting the above requirements is considered part of the building for the purpose of measuring the build-to zone.

Sec. 3.17. Rules for All Building Types

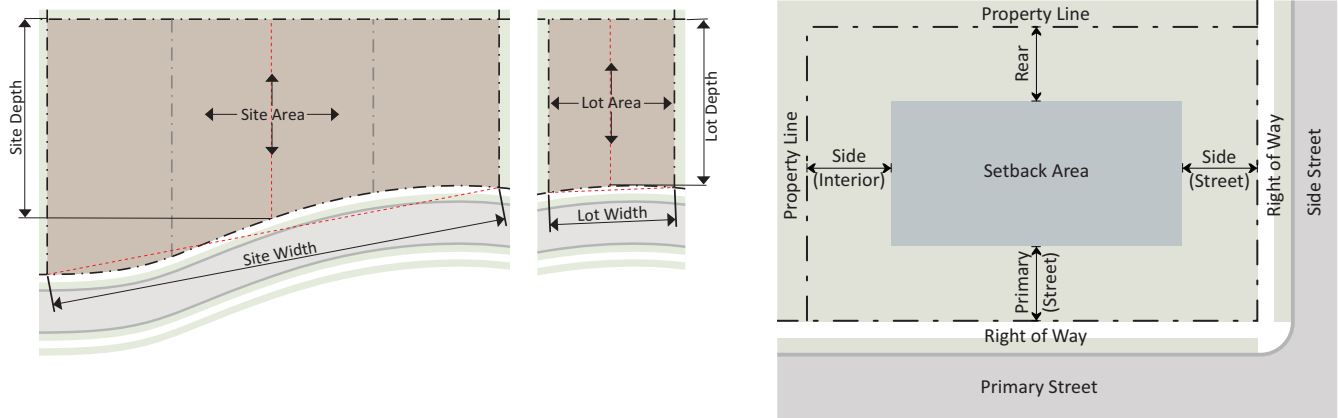

A. Site

1. Defined

A site is any lot or group of contiguous lots owned or controlled by the same person or entity, assembled for the purpose of a single development.

2. Site Area

Site area is the area included within the rear, side and front lot lines of the site. Site area does not include existing or proposed right-of-way, whether dedicated or not dedicated to public use.

3. Site Width

Site width is the distance between the side lot lines of the site (generally running parallel to a street) measured at the primary street property line along a straight line or along the chord of the property line on a curvilinear lot.

4. Site Depth

Site depth is the distance between the front and rear property lines measured along a line midway between the side property lines.

B. Lot

1. Defined

A parcel of land either vacant or occupied intended as a unit for the purpose, whether immediate or for the future, of transfer of ownership or possession, or for development.

2. Lot Area

Lot area is the area included within the rear, side and front lot lines. Lot area does not include existing or proposed right-of-way, whether dedicated or not dedicated to public use.

3. Lot Width

Lot width is the distance between the side lot lines of the lot (generally running parallel to a street) measured at the primary street property line along a straight line or along the chord of the property line on a curvilinear lot.

4. Lot Depth

Lot depth is the distance between the front and rear property lines measured along a line midway between the side property lines.

5. Lot Frontage

Every lot must have frontage upon a public street or a specified courtyard for a cottage court.

C. Building Setbacks

1. Generally

There are 4 types of setbacks – primary street, side street, side interior and rear.

2. Measurement of Building Setbacks

- Primary and side street setbacks are measured from the edge of the right-of-way.
- Side interior setbacks are measured from the side property line.

- c. When the side interior setback is 0 or 5 feet, the building or structure must be placed on the side property line or be placed a minimum of 5 feet from the side property line.
- d. Rear setbacks are measured from the rear property line or the edge of the right-of-way where there is an alley.
- e. When the rear setback is 4 or 20 feet, the building or structure must be placed exactly 4 feet from the rear property line or be placed a minimum of 20 feet from the rear property line.

3. Primary and Side Street Designation

- a. Where only one street abuts a lot, that street is considered a primary street.
- b. Where more than one street abuts a lot, all of the streets are considered primary streets, except that the following streets are designated as side streets:
 - i. 30th Avenue;
 - ii. Lorraine Street;
 - iii. 27th Avenue; and
 - iv. Adeline Street.

D. Setback Encroachments

All buildings and structures must be located at or behind required setbacks, except as listed below. Unless specifically stated no building or structure can extend into a required easement or public right-of-way.

1. Building Features

- a. Porches, stoops, balconies, galleries and awnings/canopies can extend into a required setback as stated in *Sec. 3.16. Building Elements*.
- b. Chimneys or flues may encroach up to 4 feet, provided that such extension is at least 2 feet from the vertical plane of any lot line.
- c. Building eaves, roof overhangs and light shelves may encroach up to 4 feet, provided that such extension is at least 2 feet from the vertical plane of any lot line.
- d. Bay windows, oriels and vestibules that are less than 10 feet wide may encroach up to 4 feet,

provided that such extension is at least 2 feet from the vertical plane of any lot line.

- e. Unenclosed fire escapes or stairways may encroach up to 4 feet into a required side or rear setback, provided that such extension is at least 5 feet from the vertical plane of any lot line.
- f. Unenclosed and uncovered patios, decks or terraces may encroach up to 4 feet into a required side setback or up to 8 feet into a required rear setback, provided that such extension is at least 3 feet from the vertical plane of any lot line.
- g. Cornices, belt courses, sills, buttresses or other similar architectural features may encroach up to 2 feet.
- h. Handicap ramps may encroach to the extent necessary to perform their proper function.
- i. Structures below and covered by the ground may encroach into a required setback.

2. Mechanical Equipment and Utility Lines

- a. Mechanical equipment associated with residential uses, such as HVAC units and security lighting, may encroach into a required rear or side setback, provided that such extension is at least 3 feet from the vertical plane of any lot line.
- b. Solar panels, wind turbines and rainwater collection or harvesting systems less than 10 feet in height may encroach into a required rear setback, provided that such extension is at least 5 feet from the vertical plane of any lot line.
- c. Minor structures accessory to utilities (such as hydrants, manholes and transformers and other cabinet structures) may encroach into a required rear or side setback.

3. Other Setback Encroachments

- a. *Sec. 5.2.B. Transitional Buffers.*
- b. *Sec. 5.2.D. Fences and Walls.*
- c. *Sec. 5.3. Signs.*

E. Courtyards

1. Where required, a courtyard must be one contiguous open area that meets the dimensional requirements under the specific building type.
2. A required courtyard must be provided at grade and cannot be built, parked or driven upon, except for emergency access and permitted temporary events.

F. Outdoor Amenity Space

1. Generally

Where required, outdoor amenity space must be provided on the lot and must be available for use by the occupants of the development.

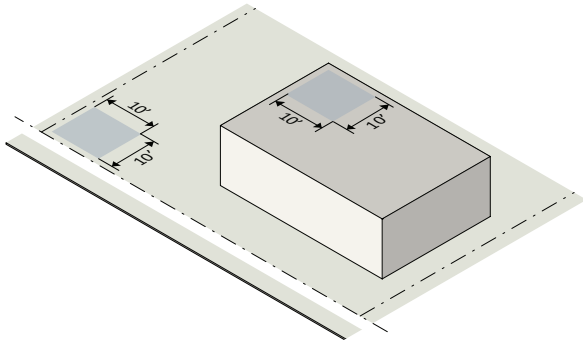

2. Standards

- a. Outdoor amenity space may be met in one contiguous open area or in multiple open areas on the lot; however, to receive credit the area must be at least 10 feet in width and length.
- b. Outdoor amenity space may be located at or above grade, except in RD-2, RA-3 and OS where outdoor amenity space must be located at grade.
- c. Active outdoor amenities include a playground, athletic court, pool deck, spray deck, promenade or dog park.
- d. Passive park areas must include improvements such as trails, paths and seating areas. Formal or informal gardens, as well as greenbelts, are considered acceptable outdoor amenity areas.
- e. Outdoor amenity space may include structures such as kiosks, bicycle racks, benches or other seating, sculpture, fountains and similar amenities. Such areas must not include signs unrelated to the amenities, utility areas, dumpsters or similar structures.

- f. Outdoor amenity space provided at grade cannot be built, parked or driven upon, except for emergency access and permitted temporary events.
- g. Outdoor amenity space provided above grade may be roofed but cannot be enclosed. Examples include a pavilion or gazebo.

G. Build-to Zone

1. Defined

- a. The build-to zone is the area on the lot where a certain percentage of the front building facade must be located, measured as a minimum and maximum setback range from the edge of the right-of-way.

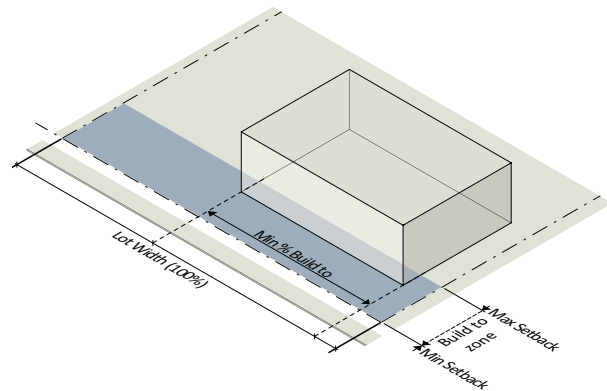

- b. The required percentage specifies the amount of the front building facade that must be located in the build-to zone, measured based on the width of the building divided by the width of the lot.
- c. The build-to requirement does not apply to a designated service street. 27th Avenue is a designated service street.

2. Corner Lots

On a corner lot, a building facade must be placed within the build-to zone for the first 30 feet along the street extending from the block corner, measured from the intersection of the two right-of-way lines.

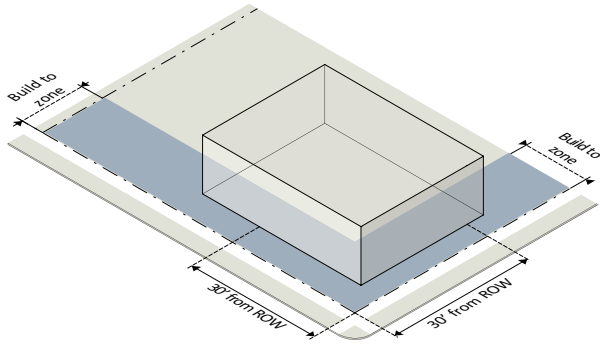

3. Uses Allowed

With the exception of parking spaces, all structures and uses allowed on the lot are allowed in the build-to zone. Does not include encroachment into a required setback unless specifically permitted.

H. Building Height

1. Building height is measured from average grade in both number of stories and feet to the top of the highest point of a pitched or flat roof.

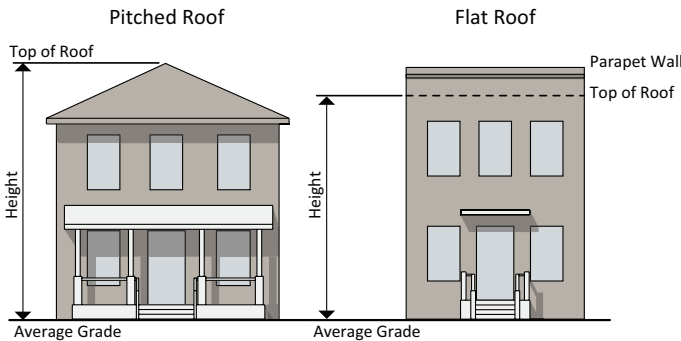

2. Average grade is determined by calculating the average of the highest and lowest elevation along natural or improved grade (whichever is more restrictive) along the front of the building parallel to the primary street setback line.

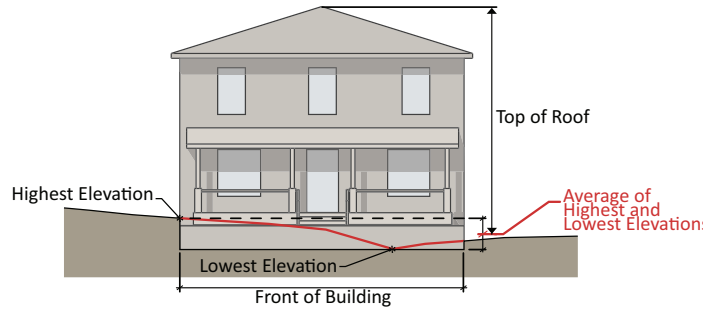

3. Where a lot slopes downward from the front property line, one story that is additional to the specified maximum number of stories may be built on the lower, rear portion of the lot.

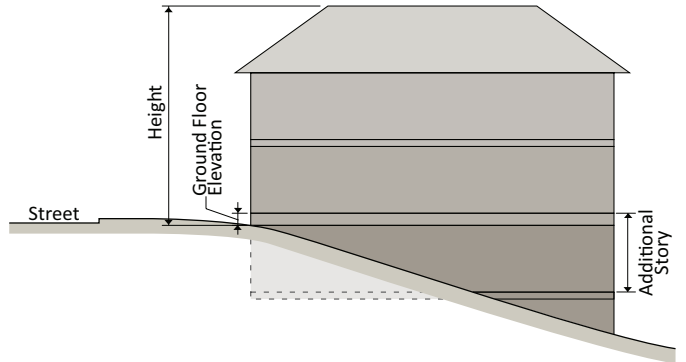

4. An attic does not count as a story where 50% or more of the attic floor area has a clear height of less than 7½ feet; measured from the finished floor to the finished ceiling.

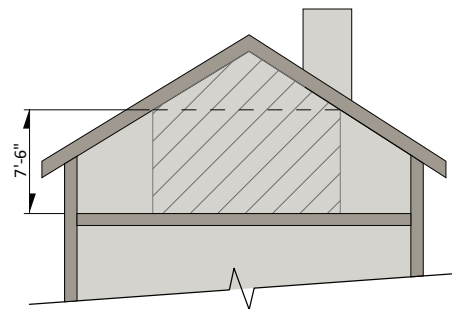

5. A basement with 50% or more of its perimeter wall area surrounded by natural grade is not considered a story.

I. Height Encroachments

Any height encroachment not specifically listed is expressly prohibited except where the Urban Development Director determines that the encroachment is similar to a permitted encroachment listed below.

1. The maximum height limits of the district do not apply to spires, belfries, cupolas, domes not intended for human occupancy; monuments, water tanks, water towers or other similar structures, which by design or function must exceed the established height limits.
2. The following accessory structures may exceed the established height limit of the district, provided they do not exceed the maximum height by more than 6 feet:
 - a. Chimney, flue or vent stack;
 - b. Flagpole;
 - c. Parapet wall; and
 - d. Solar panels or wind turbines.
3. The following accessory structures may exceed the established height limits, provided they do not exceed the maximum building height by more than 8 feet in the RD-2, RA-3, EM-2, EM-3, MX-3 Districts and 12 feet in the EM-4, EM-6, EM-9, MX-4, MX-5) Districts; do not occupy more than 25% of the roof area; and are set back at least 10 feet from the edge of the roof:
 - a. Telecommunication structure;
 - b. Unenclosed deck, patio or shade structure;
 - c. Rooftop garden, trees, landscaping;
 - d. Cooling tower;
 - e. Elevator penthouse or bulkhead;
 - f. Mechanical equipment; and
 - g. Elevator or stairway access to roof.

4. Any of the elements listed in paragraphs 2. and 3. above are considered accessory uses to the primary structure and must not be used for any purpose other than as uses incidental to the principal structures.

J. Ground Floor Elevation

1. Ground floor elevation is measured from the top of the abutting sidewalk or if no sidewalk exists, the average level of the center crown of the street to the top of the finished ground floor.
2. Minimum ground floor elevation applies to the first 30 feet of the lot measured from the right-of-way line.

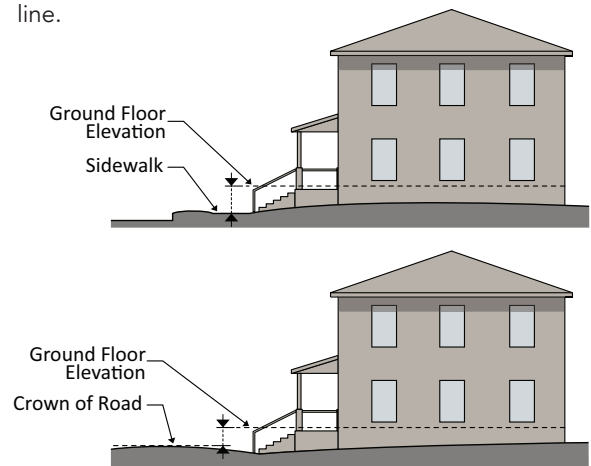

K. Story Height

1. Story height is measured from the top of the finished floor to the ceiling above.

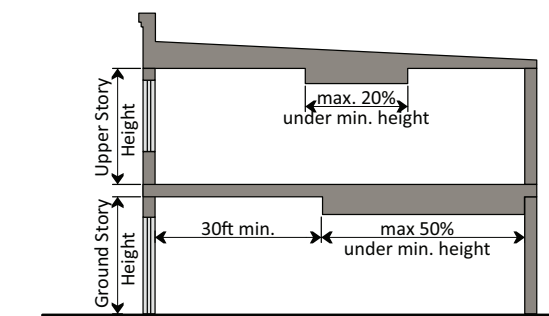

2. Minimum ground story height applies to the first 30 feet of the building measured inward from the street-facing facade. At least 50% of the ground story must meet the minimum height provisions.
3. At least 80% of each upper story must meet the minimum upper story height provisions.

L. Transparency

1. The minimum percentage of windows and doors that must cover a ground story facade is measured between 2 and 12 feet above the abutting sidewalk.



2. The minimum percentage of windows and doors that must cover an upper story facade is measured from the top of the finished floor to the top of the finished floor above. When there is no floor above, upper story transparency is measured from the top of the finished floor to the top of the wall plate.
3. Transparency applies to primary and side street-facing facades only.
4. Glass is considered transparent where it has a transparency higher than 80% and external reflectance of less than 15%.
5. Windows cannot be made opaque by window treatments (except operable sunscreen devices within the conditioned space).

M. Blank Wall Area

1. Blank wall area means a portion of the exterior facade of the building that does not include: windows or doors; columns, pilasters or other articulation greater than 12 inches in depth; or a substantial material change (paint color is not considered a substantial change).

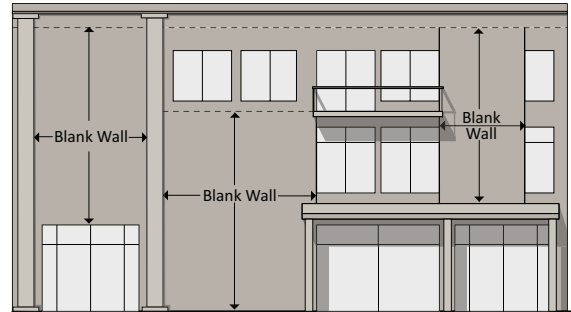

2. Blank wall area applies in both a vertical and horizontal direction.
3. Blank wall area applies to ground and upper story primary and side street-facing facades.

N. Pedestrian Access

1. An entrance providing both ingress and egress, operable to residents or customers at all times, is required to meet the street-facing entrance requirements. Additional entrances off another street, pedestrian area or internal parking area are permitted.
2. The entrance spacing requirements must be met for each building, but are not applicable to adjacent buildings.
3. An angled entrance may be provided at either corner of a building along the street to meet the street-facing entrance requirements.

O. Protected Districts

1. Applicability

- a. Any protected district triggers the application of the following requirements.
- b. A protected district is defined as any R-1A, R-1B, R-1C or R-2 district.

2. Bulk Plane

A bulk plane is required where a Midtown Form-Based Code District abuts a protected district. When abutting a protected district, a building must not extend into a 45-degree angular plane projecting over the subject property measured from a height of 35 feet at the side interior or rear setback line.

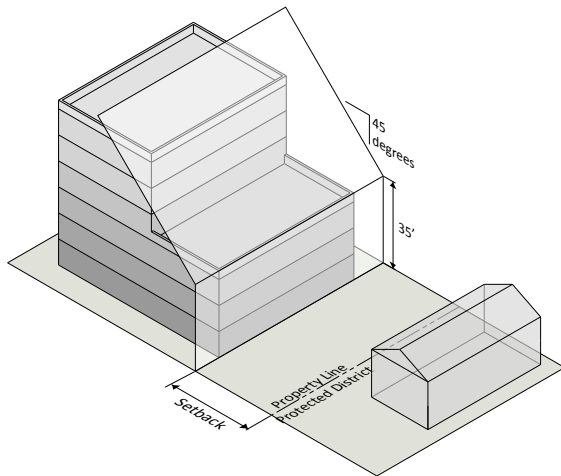

3. Buffer Strip

A buffer strip meeting the standards of Sec. 5.2. *Landscaping and Screening* is required where a Midtown Form-Based Code District abuts a protected district.

P. Building Materials

1. Applicability

The requirements of this section apply to all building facades.

2. Primary Materials

The following materials are required for not less than 75% of the building wall surface area on each facade:

- a. Brick;
- b. Cementitious siding;
- c. Glass curtain wall;
- d. Stone;
- e. Stucco (cementitious finish); and
- f. Wood (only permitted in RD-2).

3. Material Change

Primary material changes must occur only at inside corners.

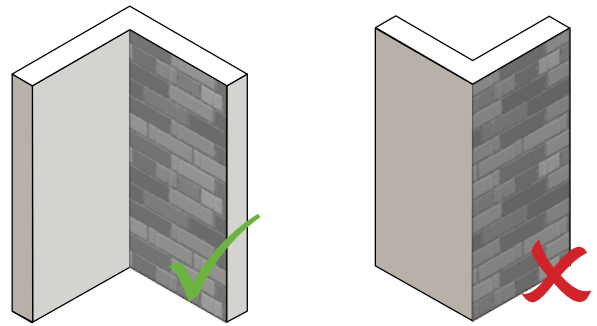

4. Accent Materials

The following materials may make up 25% of the building wall surface area on each facade:

- a. Cementitious siding;
- b. External Insulation Finishing System - EIFS (for trim and cornice elements only);
- c. Glass block;
- d. Gypsum Reinforced Fiber Concrete (GFRC— for trim elements only);
- e. Metal (for beams, lintels, trim elements and ornamentation only);
- f. Pre-cast masonry (for trim and cornice elements only);
- g. Split-faced block (for piers, foundation walls and chimneys only); and,
- h. Wood – for trim elements in all districts and for siding or shingles in the RD-2.

5. Alternate Materials

Alternate building materials or those not normally permitted as primary materials may be approved by the Midtown Development Review Committee.

Page Intentionally Left Blank

Article 4. Land Use

Sec. 4.1. Permitted Uses

- A. This Article establishes the uses allowed in each district. A lot or building must be occupied with only the uses allowed on the permitted use table in *Sec. 4.4. Permitted Use Table*.
- B. Any one or more land uses allowed in a district may be established on any lot within that district, subject to the permitted use table and in compliance with all applicable requirements of the Midtown Form-Based Code.

Sec. 4.2. Principal Uses

- A. If a proposed use is not listed in the permitted use table, but is similar to a listed use, the Urban Development Director may allow the proposed use. When determining whether a proposed use is similar to a listed use, the Urban Development Director will consider the following criteria:
 1. The actual or projected characteristics of the proposed use;
 2. The relative amount of site area or floor area and equipment devoted to the proposed use;
 3. Relative amounts of sales;
 4. The customer type;
 5. The relative number of employees;
 6. Hours of operation;
 7. Building and site arrangement;
 8. Types of vehicles used and their parking requirements;
 9. The number of vehicle trips generated;
 10. Signs;
 11. How the proposed use is advertised;
 12. The likely impact on surrounding properties; and
 13. Whether the activity is likely to be independent of the other activities on the site.
- B. Where a use is determined not to be similar to any listed use, a text amendment is required prior to establishment of that use.

Sec. 4.3. Accessory Uses

- A. Accessory uses and structures are permitted in conjunction with an allowed principal use. Accessory uses and structures must be accessory and clearly incidental and subordinate to a permitted principal use or structure.
- B. No accessory use or structure may be established prior to the establishment of a permitted principal use or structure.
- C. All accessory structures must meet the setback and height requirements of *Article 3. Building Types*. Minimum height requirements do not apply.
- D. The Urban Development Director is authorized to determine when a use or structure is accessory. In order to classify a use or structure as accessory, the Urban Development Director must determine that the use or structure:
 1. Is subordinate to the principal use in terms of area, extent and purpose;
 2. Contributes to the comfort, convenience or necessity of occupants of the principal use or structure served;
 3. Is located on the same lot as the principal use or structure or on a contiguous lot in the same ownership;
 4. Does not involve operations not in keeping with the character of the principal use or structure served; and
 5. Is not of a nature likely to attract visitors in larger numbers than would normally be expected for the principal use or structure.

Sec. 4.4. Permitted Use Table

Uses are allowed by district as set forth below.

	MX -3, -4, -5	EM -2, -3	EM -4, -6, -9	RA -3	RD -2	OS	Definition/ Use Standard
Residential Uses							
Dwelling, detached	X	X	X	P	P	X	Sec. 4.5.A.1
Dwelling, attached	P	P	X	P	X	X	Sec. 4.5.A.2
Dwelling, multi-family	P	P	X	P	X	X	Sec. 4.5.A.3
Assisted living facility, nursing home	P	P	P	X	X	X	Sec. 4.5.A.4
Bed and breakfast residence (up to 5 rooms)	P	P	X	P	PC	X	Sec. 4.5.A.5
Bed and breakfast inn (6 to 12 rooms)	P	P	P	PC	X	X	Sec. 4.5.A.6
Day care center	P	P	P	PC	X	X	Sec. 4.5.A.7
Independent living facility	P	P	P	X	X	X	Sec. 4.5.A.8
Retail Uses							
Amusement and recreation facilities, indoor	P	P	P	X	X	X	Sec. 4.5.B.1
Art gallery	P	P	P	L	X	X	Sec. 4.5.B.2
Bank	P	P	P	X	X	X	Sec. 4.5.B.3
Bar, lounge	P	X	X	X	X	X	Sec. 4.5.B.4
Personal service	P	X	X	L	X	X	Sec. 4.5.B.5
Professional studio, photography, drama, dance, gymnastics	P	X	X	X	X	X	Sec. 4.5.B.6
Repair service	P	X	X	L	X	X	Sec. 4.5.B.7
Restaurant	P	X	X	L	X	X	Sec. 4.5.B.8
Retail sales	P	X	X	L	X	X	Sec. 4.5.B.9
Commercial Uses							
Ambulance service	P	P	P	X	X	X	Sec. 4.5.C.1
Hotel, motel (13 or more rooms)	P	X	X	X	X	X	Sec. 4.5.C.2
Hospice	P	P	P	X	X	X	Sec. 4.5.C.3
Hospital	X	P	P	X	X	X	Sec. 4.5.C.4
Medical clinic, office	P	P	P	X	X	X	Sec. 4.5.C.5
Office	P	P	P	L	X	X	Sec. 4.5.C.6
Parking lot or garage	PC	PC	PC	X	X	X	Sec. 4.5.C.7
Veterinary clinic	L	L	L	X	X	X	Sec. 4.5.C.8

Key: P = Permitted by-right
 PC = Planning Commission review required
 L = Use permitted subject to use standards specified in cross-reference
 X = Not permitted

Note: None of the above permitted uses include an "adult entertainment establishment" as defined in the Land Development Code.

	MX -3, -4, -5	EM -2, -3	EM -4, -6, -9	RA -3	RD -2	OS	Definition/ Use Standard
Civic Uses							
Amphitheater	X	X	X	X	X	P	Sec. 4.5.D.1
College, university	P	P	P	X	X	X	Sec. 4.5.D.2
Museum, library	P	P	P	X	X	X	Sec. 4.5.D.3
Park, playground	P	P	P	P	P	P	Sec. 4.5.D.4
Place of worship	P	P	P	PC	PC	X	Sec. 4.5.D.5
School, K-12	P	P	P	PC	PC	X	Sec. 4.5.D.6
Semi-public use	P	P	P	X	X	X	Sec. 4.5.D.7
Accessory Uses							
Drive-thru	PC	PC	PC	X	X	X	Sec. 4.5.E.1
Carriage house	X	X	X	P	P	X	Sec. 4.5.E.2
Home care center	P	P	P	P	P	X	Sec. 4.5.E.3
Home occupation	L	L	L	L	L	X	Sec. 4.5.E.4
Utility service	P	P	P	P	P	X	Sec. 4.5.E.5

Key: P = Permitted by-right
 PC = Planning Commission review required
 L = Use permitted subject to use standards specified in cross-reference
 X = Not permitted

Note: None of the above permitted uses include an "adult entertainment establishment" as defined in the Land Development Code.

Sec. 4.5. Use Definitions

The following uses are defined for the purpose of this Code. If there is a conflict between a definition contained in Sec. 5 of the Land Development Code and this Code, the definition in this Code controls.

A. Residential Uses

1. Dwelling, Detached

One dwelling that is not attached to any other dwelling by any means.

2. Dwelling, Attached

Two or more dwellings attached by common vertical walls in a single building. Dwellings cannot be vertically mixed.

3. Dwelling, Multi-family

Three or more attached dwellings vertically or horizontally mixed in a single building.

4. Assisted Living Facility, Nursing Home

A facility for the elderly or disabled that provides, nursing care for the majority of residents, as well as assistance with activities of daily living such as supervision of medication, eating, bathing and dressing.

5. Bed and Breakfast Residence

A facility where overnight accommodations for up to 5 rooms are provided for compensation, with or without a morning meal for guests and where the manager of the facility lives on the premises.

6. Bed and Breakfast Inn

A facility where overnight accommodations for between 6 and 12 rooms are provided for compensation, with or without a morning meal for guests and where a manager of the facility lives on the premises.

7. Day Care Center

A facility that provides care for 5 or more persons regardless of age, not related by blood or marriage. Care cannot exceed 12.5 hours for any in single 24-hour period.

8. Independent Living Facility

A facility for the elderly or disabled that does not typically provide nursing care or assistance with activities of daily living such as supervision of medication, eating, bathing and dressing.

B. Retail Uses

1. Amusement and Recreation Facilities, Indoor

A facility providing recreation-oriented activities in an indoor setting including amusement center, bowling alley, dance hall, game/video arcade, health gym or spa, pool hall, ice or roller skating rink, inflatable playground, movie theater, indoor theater or any other similar use.

2. Art Gallery

- a. A facility that contains a room or series of rooms where works of art are exhibited on a regular basis.
- b. An art gallery is permitted in RA-3 subject to the following:
 - i. The use must be located on the first floor of a stacked flat;
 - ii. The stacked flat must be on a lot located at the intersection of two public streets; and
 - iii. The use cannot exceed 1,500 square feet in gross floor area.

3. Bank

A facility where money is deposited and withdrawn and where excess funds are invested or supplied for loans.

4. Bar, Lounge

A facility whose primary service is to provide alcoholic drinks to patrons for consumption on the premises in accordance with Mississippi Code 67-1-5 and City ordinances. See Section 73, Alcoholic Beverage Sales.

5. Personal Services

- a. A facility that provides personal service including barber or beauty shop, copy center, nail salon, dry cleaners, tutoring, optometrist, photo finishing, tanning salon, tax services or any other similar uses.

- b. A personal service use is permitted in RA-3 subject to the following:
 - i. The use must be located on the first floor of a stacked flat;
 - ii. The stacked flat must be on a lot located at the intersection of two public streets; and
 - iii. The use cannot exceed 1,500 square feet in gross floor area.

6. Professional Studio, Photography, Drama, Dance, Gymnastics

A facility that provides professional instruction in a studio setting including photography, drama, yoga, dance, gymnastics, martial arts or other similar uses.

7. Repair Service

- a. A facility that provides repair services to bicycles, scooters, clothes, clocks, computers, phones, jewelry, musical instruments, office equipment, radios, shoes, televisions, watches or other similar items. Does not include repairs to cars or trucks.
- b. A repair service use is permitted in RA-3 subject to the following:
 - i. The use must be located on the first floor of a stacked flat;
 - ii. The stacked flat must be on a lot located at the intersection of two public streets; and
 - iii. The use cannot exceed 1,500 square feet in gross floor area.

8. Restaurant

- a. A facility whose primary service is to provide food and drink for patrons for consumption on the premises or for take out. Beverages containing alcohol may also be sold and consumed within the confines of the structure in conjunction with the food service and must meet Mississippi Code 67-1-5 and City ordinances. See Section 73, Alcoholic Beverage Sales. Examples of these types of restaurants include cafe, coffee or tea shop, cafeteria, delicatessen, pizza delivery, yogurt or ice cream shop or other similar use.

- b. A restaurant is permitted in RA-3 subject to the following:
 - i. The use must be located on the first floor of a stacked flat;
 - ii. The stacked flat must be on a lot located at the intersection of two public streets; and
 - iii. The use cannot exceed 1,500 square feet in gross floor area.

9. Retail Sales

- a. A facility that sells, rents or leases antiques, art supplies, baked goods, bicycles, books, cameras, floor coverings, footwear, crafts, clothing, computers, convenience goods, electronics, fabric, flowers, groceries, hardware, home furnishings, ice cream, jewelry, medicine, medical supplies, music, musical instruments, office supplies, package shipping, pet supplies, pharmaceuticals, picture frames, plants, printed materials, produce, scooters, small appliances, souvenirs, sporting goods, stationery, videos or other similar products.
- b. A retail sales use is permitted in RA-3 subject to the following:
 - i. The use must be located on the first floor of a stacked flat;
 - ii. The stacked flat must be on a lot located at the intersection of two public streets; and
 - iii. The use cannot exceed 1,500 square feet in gross floor area.

C. Commercial Uses

1. Ambulance Service

A facility that operates ambulances providing medical transportation to persons who are ill or injured or who have disabilities.

2. Hotel, Motel

A facility where overnight accommodations for 13 or more rooms are provided for compensation.

3. Hospice

A facility that provides palliative and supportive medical and other health services to meet the physical, psychological, social, spiritual and special needs of terminally ill patients and their families.

4. Hospital

A facility where sick or injured persons are given medical care and may be housed overnight, fed and provided nursing and related services.

5. Medical Clinic, Office

A facility containing the offices of one or more practitioners providing medical, dental, psychiatric, osteopathic, chiropractic, physical therapy or similar services for outpatients only, with or without shared or common spaces and equipment.

6. Office

- a. A facility used for activities conducted in an office setting and generally focusing on business, professional or financial services. Office includes the following.
 - i. Business services including, but not limited to, advertising, business management consulting, computer or data processing, graphic design, commercial art or employment agency.
 - ii. Professional services including, but not limited to, lawyer, accountant, auditor, bookkeeper, engineer, architect, sales office, travel agency, interior decorator or security system services
 - iii. Financial services including but not limited to, lender, investment or brokerage house, call center, insurance adjuster, real estate or insurance agent, mortgage agent or collection agency.
 - iv. Also includes trade, vocational and business schools.
- b. An office is permitted in RA-3 subject to the following:
 - i. The use must be located on the first floor of a stacked flat;
 - ii. The stacked flat must be on a lot located at the intersection of two public streets; and
 - iii. The use cannot exceed 1,500 square feet in gross floor area.

7. Parking Lot or Garage

A facility that provides parking as a principal use on the site. A fee may or may not be charged.

8. Veterinary Clinic

- a. A facility designed or arranged for the care of animals without any outdoor activity.
- b. No outdoor activity associated with care of animals is allowed

D. Civic Uses**1. Amphitheater**

A facility, usually circular or oval, in which tiers of seats rise from a central open arena, where outdoor performances are held.

2. College, University

- a. A public institution of higher education having authority to award bachelor's and post-graduate degrees.
- b. A college, university is allowed to use the civic building type dimensional standards (see Sec. 3.6. *Civic Building*).

3. Museum, Library

- a. A public facility serving as a repository for a collection of books, natural, scientific, literary curiosities or objects of interest or works of art arranged, intended and designed to be viewed by members of the public.
- b. A museum, library is allowed to use the civic building type dimensional standards (see Sec. 3.6. *Civic Building*).

4. Park, Playground

An area used for outdoor play or recreation, often containing recreational equipment such as slides, swings, climbing frames, ballfields, basketball courts and swimming pools. May include both passive and active recreation.

5. Place of Worship

- a. A facility that by design and construction is intended for conducting organized religious services including churches, chapels, synagogues, temples, mosques or other similar uses.

- b. A place of worship is allowed to use the civic building type dimensional standards (see Sec. 3.6. *Civic Building*).

6. School, K-12

- a. A public or private institution that persons are instructed in the specifics of learning including kindergarten, elementary grades 1-6, junior high grades 7-9 and secondary senior high grades 10-12. Included in this definition is any facility operating as kindergarten, nursery school, Head Start or like facility in conjunction with an elementary and/or secondary school system, whether it be public, private or parochial, whose primary purpose is a structured school readiness program.
- b. A school, K-12 is allowed to use the civic building type dimensional standards (see Sec. 3.6. *Civic Building*).

7. Semi-Public Use

A use owned, operated and/or maintained by a private, eleemosynary institute or other group generally for the benefit of a selected public group and the community (i.e. religious group).

E. Accessory Uses

1. Drive-Thru

An accessory facility that allows customers to be served while sitting in a vehicle, typically associated with drive-thru restaurants, banks, pharmacies and dry cleaners.

2. Carriage House

A small self-contained accessory dwelling unit located on the same lot as a detached house but physically separated for use as a complete, independent living facility, with provisions for cooking, sanitation and sleeping.

3. Home Care Center

A private establishment that provides care for up to 4 persons regardless of age, not related by blood or marriage. Care cannot exceed 12.5 hours for any in single 24-hour period. A home care center is a home occupation.

4. Home Occupation

- a. A home occupation that provides a service or product that is conducted wholly within a residential dwelling.
- b. The home occupation must meet the requirements of LDC Sec. 82.

5. Utility Service

Public or private infrastructure, including but not limited to water, sewer, gas, electric, telephone, Internet, cable and other similar services serving a limited area with no on-site personnel.

Article 5. Site Development

Sec. 5.1. Parking

A. Applicability

1. General

No permit for the construction, reconstruction, extension or alteration of any building, structure or use of land and no building or land, or any part of any building or land, may be occupied or used until parking has been provided in accordance with the requirements of this Code.

2. Additions

- a. A building or site may be renovated or repaired without providing additional parking, provided there is no increase in gross floor area or improved site area.
- b. When a building, use or site is increased in gross floor area or improved site area, parking is required for the additional floor or site area only.
- c. When the gross floor area or improved site area is increased by more than 50% cumulatively, both the existing use and the additional floor or site area must conform to the parking requirements of this Code.

3. Change in Use

- a. A change in use must comply with the parking requirements unless the use has the same or a lesser parking demand than the previous use.
- b. Where required parking spaces for the new use exceed the required parking spaces for the existing use, additional parking is only required for the difference between the current parking spaces required and the parking spaces required for the new use.

B. Vehicle Parking

1. The following minimum vehicle parking spaces are required.

Use	Required Spaces
Residential: 0-1 bedroom	1 per unit
Residential: 2+ bedrooms	2 per unit
Dwelling units restricted to residents 62 years and older	0.5 per unit
Bar, lounge, restaurant	1 per 200 square feet of gross floor area
Hospital	1 parking space per bed and 1 per peak employee on weekday shift
Hotel, motel	1 per guest room - excluding bars, lounges and restaurants, which must be computed separately
Medical clinic, office	1 per 250 square feet of gross floor area
All other uses:	1 per 500 square feet of gross floor area

2. Outdoor dining areas that are located in the build-to zone or a forecourt allowed under Sec. 3.16. *Building Elements* are exempt from the calculation of required vehicle parking spaces.
3. In each parking lot or garage containing over 100 parking spaces, at least 2 spaces within the 10 spaces closest to the primary entrance to the building must be reserved for a hybrid or electric vehicle and must have a sign indicating that reservation.

C. Location of Parking

Required vehicle parking must be located on the same lot as the use they are intended to serve, except as listed below.

1. On-Street Parking

- a. One on-street parking space may be substituted for every required parking space, provided the on-street space is located on a public right-of-way immediately abutting the subject property.
- b. Each on-street parking space may only be counted for one property. Where a space straddles an extension of a property line, the space may only be counted by the owner whose property abuts 50% or more of the on-street parking space.

2. Remote Off-Site Parking

- a. All required parking spaces, except required accessible spaces, can be located off-site if the remote parking area is located within 660 feet from the primary entrance of the use served.
- b. Up to 50% of the required parking spaces can be located between 660 feet and 1,320 feet from the primary entrance of the use served.
- c. All remote parking spaces used to meet an on-site parking requirement must be located within the boundaries of the Midtown Form-Based Code District.
- d. All remote parking must have a City-approved remote parking agreement as part of the approved site plan.
- e. The remote parking area is measured in walking distance from the nearest point of the remote parking area to the primary entrance of the use served.

D. Bicycle Parking

1. Required Spaces

The following minimum bicycle parking spaces are required.

Use	Required Short-Term Spaces	Required Long-Term Spaces
Dwelling, multi-family	1 per 20 units, 3 min	1 per 5 units (projects with 10+ units only)
All other residential uses	none required	none required
All retail uses	1 per 5,000 SF of gross floor area, 3 min	1 per 5,000 SF of gross floor area
All commercial uses	1 per 10,000 SF of gross floor area, 3 min	1 per 5,000 SF of gross floor area
All civic uses	1 per 5,000 SF of gross floor area, 3 min	none required

2. Bicycle Parking Facilities

Bicycle parking may be provided through various types of facilities, provided the facility meets the following:

- a. Each required bicycle parking space is at least 2 feet by 6 feet;
- b. Bicycle racks are securely anchored, are easily usable with both U-locks and cable locks and support a bicycle at two points of contact to prevent damage to the bicycle wheels and frame;
- c. Where a bike can be locked on both sides without conflict, each side can be counted as a required space;
- d. Spacing of the racks provide clear and maneuverable access; and
- e. Facilities may be placed on private property or within the public right-of-way. Facilities in the right-of-way must be approved by the City Engineer.

3. Short-Term Bicycle Parking

Bicycle racks must be publicly accessible and be located no more than 100 feet from the building entrance the bicycle rack is intended to serve.

4. Long-Term Bicycle Parking

- a. Long-term bicycle parking must be covered and weather resistant.
- b. Required spaces can be in the form of a covered bicycle rack, in a locker, within a building or within a parking structure.

E. Drive-Thru Vehicle Stacking

- 1. Adequate space must be made available on-site for the stacking, storage and queuing of vehicles.
- 2. Where allowed, vehicles using drive-thru facilities may not encroach on or interfere with the public use of streets and sidewalks by vehicles or pedestrians.
- 3. Where allowed, all drive-thru areas, including but not limited to menu boards, stacking lanes, trash receptacles, ordering box, drive up windows and other objects associated with the drive-thru area, must be located to the side or rear of the building. Drive-thru windows and lanes may not be placed between the street and the associated building.
- 4. No drive-thru window or lane is permitted on the side of a building facing a protected district.
- 5. A restaurant with a drive-thru must provide at least 4 queuing spaces, measured from the first pick up window the vehicle encounters in the drive-thru.
- 6. A bank or pharmacy with a drive-thru must provide at least 2 queuing spaces per drive-thru lane, measured from the teller box or window.
- 7. A dry cleaner with a drive-thru must provide a minimum of 3 spaces measured from the pick up door.
- 8. All other uses will be determined by the Urban Development Director.

F. Stall Size and Drive Aisle Dimensions

- 1. Parking spaces and drive aisles must meet the following dimensions. Parking spaces and drive aisles using dimensions other than those specified may be used if approved by the Urban Development Director.

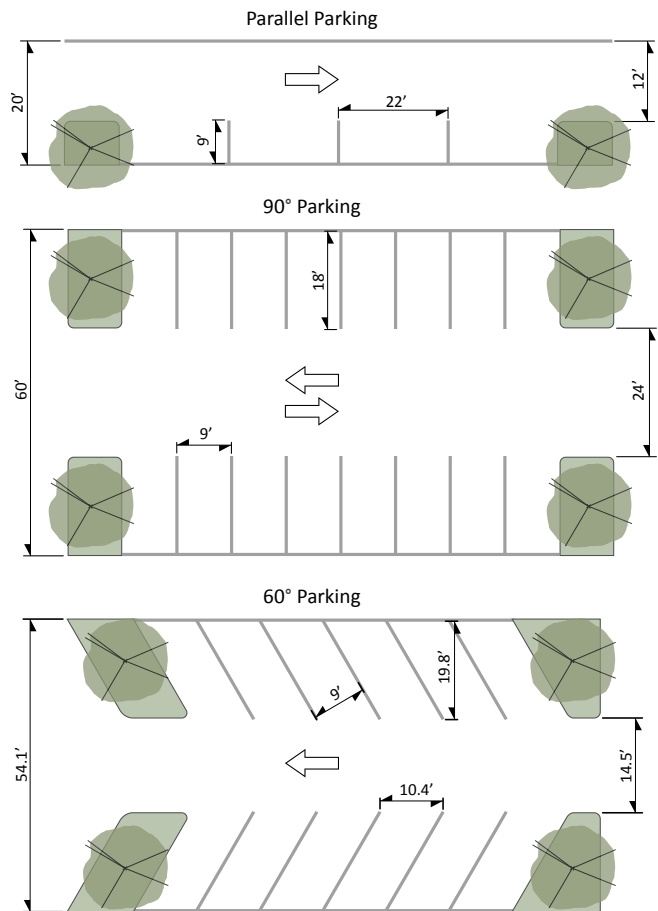

- 2. Within a structured parking garage, up to 30% of the total parking spaces provided may be compact spaces. No more than 2 compact parking spaces may abut each other. Compact spaces may be reduced to 8 feet in width. All compact parking spaces must be clearly and visibly striped and labeled for compact car use only.

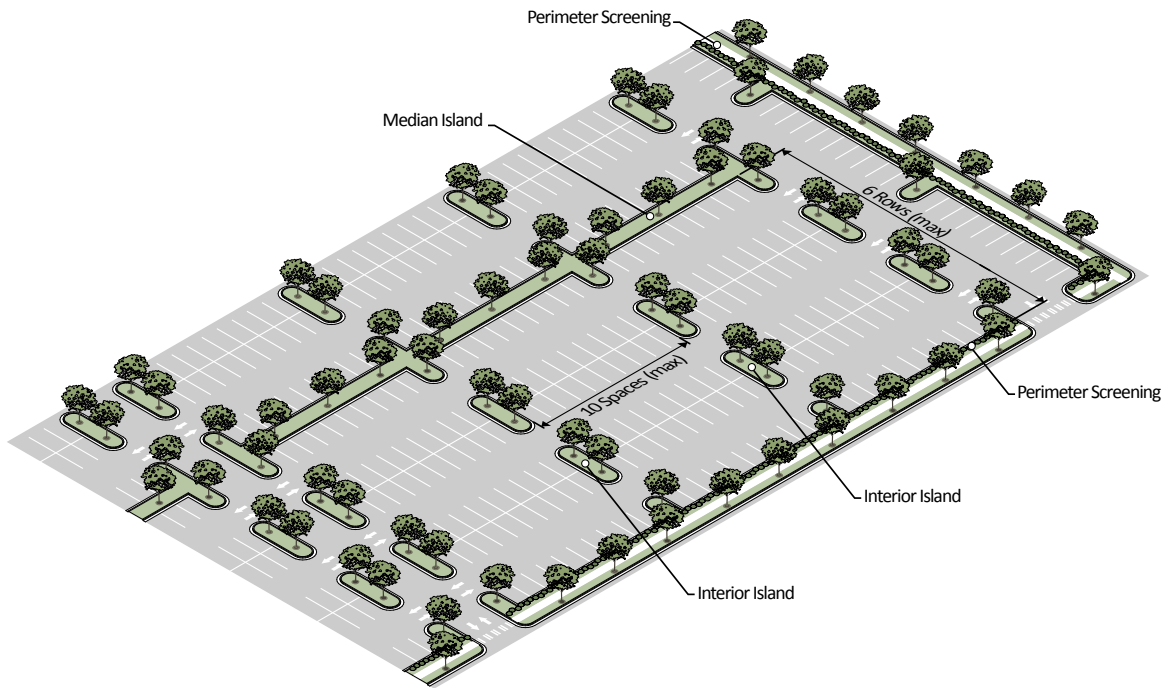

G. Parking Lot Landscaping

1. Applicability

- a. This section applies to all on-site surface parking lots with more than 10 spaces, except as provided under paragraph 2. below. For purposes of this section, multiple platted lots contained on a single site plan and any separate parking areas connected with drive aisles are considered a single parking area.
- b. An existing parking lot may be renovated or repaired without providing additional landscaping, provided there is no increase in the size of the parking lot.
- c. When an existing parking lot square footage is increased in area by more than 10% cumulatively, landscaping is required for the new parking area only.
- d. When an existing parking lot square footage is increased by more than 50% cumulatively, landscaping is required for both the existing parking lot and the new parking area.

2. Perimeter Screening

All surface parking lots with frontage on any portion of a street right-of-way (not including an alley) must be screened with the following:

- a. A minimum 10-foot wide, landscaped area with a continuous row of shrubs must be provided between the street and parking lot.
- b. Shrubs must be a minimum of 18 inches in height when planted and must reach a minimum size of 36 inches in height within 3 years of planting.
- c. The required 10-foot landscaped area may be reduced to 5 feet when a 3-foot high masonry wall is erected.
- d. Breaks for bicycle, pedestrian and vehicle access are allowed.

3. Interior Islands

- a. A landscaped interior island must be provided every 10 parking spaces. Interior islands must be distributed evenly throughout the parking area.

- b. Interior islands may be consolidated or intervals may be expanded in order to preserve existing trees.
- c. An interior island must be a minimum of 9 feet in width and 320 square feet in area.
- d. Interior islands must be installed below the level of the parking lot surface to allow for runoff capture.

4. Median Islands

- a. A landscape median island must be provided between every 6 single parking rows.
- b. A landscape median island must be a minimum of 5 feet wide.
- c. A median island may also serve as the location for a sidewalk. In such case, the sidewalk must be a minimum of 6 feet wide and the remaining planting area must be no less than 5 feet wide.
- d. Median islands may be consolidated or intervals may be expanded in order to preserve existing trees.
- e. Median islands not containing a sidewalk must be installed below the level of the parking lot surface to allow for runoff capture.

5. Tree Coverage

- a. Each interior island must include at least 2 shade trees.
- b. In no case can there be less than 1 tree for every 3,000 square feet of parking area, including drive lanes.

6. Maintenance and Installation

All required landscaping must meet the maintenance, installation and intersection visibility requirements of *Sec. 5.2. Landscaping and Screening*.

H. Surfacing

1. Impervious Materials

Where on-site facilities are provided for parking or any other vehicular use areas, they must be surfaced with asphalt bituminous concrete or other type of dustless material approved by the City Engineer and maintained in a smooth, well-graded condition.

2. Pervious Materials

Pervious or semi-pervious parking area surfacing materials may be approved by the City Engineer. Permitted materials may include but are not limited to grass, "grasscrete", ring and grid systems used in porous or grid pavers.

3. Curbs and Drainage

- a. All surface parking areas must be graded and drained to collect, retain and infiltrate surface water accumulation on-site to the greatest extent practicable.
- b. Curbs or parking blocks are required at the edges of perimeter and interior landscaped areas. Curbing must have openings to allow drainage to enter and percolate through the landscaped area.

I. Design of Parking Structures

- 1. The ground story of a structured parking garage must have active uses (such as, but not limited to, residential, commercial, office or civic space) located between the parking structure and the street (not including an alley or designated service street).
- 2. Where upper stories of structured parking are located at the perimeter of a building, they must be screened so that cars are not visible from ground level view from adjacent property or adjacent public street right-of-way (not including an alley or designated service street).
- 3. 27th Avenue is a designated service street.
- 4. All floors fronting a public street right-of-way (not including an alley or designated service street) must be level (not inclined).

5. Sloped ramps cannot be discernible along the perimeter of the parking structure.
6. Ground floor facade treatment (building materials, windows and architectural detailing) must be continued on upper stories.

J. Vehicle Loading Areas

1. Loading Not Required

If determined necessary by the Urban Development Director, adequate space must be made available on-site for the unloading and loading of goods, materials, items or stock for delivery and shipping.

2. Location

If a loading area is provided, it must meet the following standards.

- a. The loading area must be located on the same lot occupied by the use served and must be accessible from a public street or alley.
- b. The loading area must be located to the side or rear of buildings and be screened. Loading areas may not be placed between the street and the associated building.
- c. With the exception of areas specifically designated by the City, loading and unloading activities are not permitted in the public right-of-way.
- d. Loading and unloading activities may not encroach on or interfere with the use of sidewalks, drive aisles, queuing areas and parking areas by vehicles or pedestrians.

K. Accessible Parking

If parking spaces are provided for self-parking by visitors or employees, then accessible spaces must be provided in each such parking area in conformance with the table below. Spaces required by the table need not be provided in the particular lot. They may be provided in a different location if equivalent or greater accessibility, in terms of distance from an accessible entrance, cost and convenience is ensured.

Spaces in Parking Lot	Accessible Spaces
1 to 25	1
26 to 50	2
51 to 75	3
76 to 100	4
101 to 150	5
151 to 200	6
201 to 300	7
301 to 400	8
401 to 500	9
501 to 1,000	2% of total

Sec. 5.2. Landscaping and Screening

A. Applicability

1. General

No permit for the construction, reconstruction, extension or alteration of any building, structure or use of land and no building or land, or any part of any building or land, may be occupied or used until landscaping and screening has been provided in accordance with the requirements of this Code.

2. Additions

- a. A building or site may be renovated or repaired without providing additional landscaping and screening, provided there is no increase in gross floor area or improved site area.
- b. When the gross floor area or improved site area is increased, landscaping and screening is required for the additional floor or site area only.
- c. When the gross floor area or improved site area is increased by more than 50% cumulatively, both the existing use and the additional floor or site area must conform to the landscaping requirements of this Code.

3. Change in Use

A buffer may be required for a change in use under *Sec. 5.2.B. Transitional Buffers*. Otherwise, a change in use does not trigger application of this section.

B. Transitional Buffers

1. Applicability

The following transitional buffer requirements apply along a perimeter lot line that abuts a protected district (any R-1A, R-1B, R-1C or R-2 District).

2. General

- a. A required buffer strip must be located within the outer perimeter of the lot, parallel to and extending to the property boundary line and must be provided along the entire lot immediately abutting the property line.

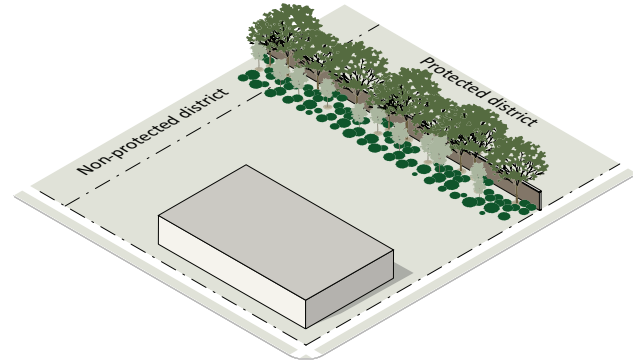

- b. The width of a buffer strip is determined exclusive of any required setback; however, the required buffer strip may be located wholly or partially within a required setback.
- c. The parking of vehicles and the placement of buildings is not allowed in a buffer strip. All required setbacks apply.
- d. No building may be located closer than 10 feet to a buffer strip.
- e. Breaks for pedestrian, bicycle and vehicle access are allowed, as approved by the Urban Development Director.

3. Walls

Walls in a buffer strip must meet the following:

- a. Walls must be constructed of high quality materials including one or a combination of the following: decorative blocks; brick; stone; cast-stone; split-faced block; stucco over standard concrete masonry blocks; glass block; or other material approved by the Midtown Development Review Committee.
- b. No walls containing more than 50% exposed standard concrete masonry blocks are allowed, whether painted or not.
- c. No wall can be located within any required drainage or utility easement.

4. Fences

Fences in a buffer strip must meet the following:

- a. Fences must be opaque and be constructed of high quality materials including one or a combination of the following: wood, composite fencing; or other material approved by the Midtown Development Review Committee.

- b. The finished face must be located towards the adjacent property.
- c. Fences that use wooden support posts must be set in a masonry support column at least every 40 feet.
- d. No fence can be located within any required drainage or utility easement.

5. Buffer Materials

- a. In the buffer strip, 50% of required trees must be a locally adapted evergreen species recognized by the State of Mississippi Division of Forestry, as being acceptable for Midtown.
- b. Shrubs must be evergreen and be of a species that under typical conditions can be expected to reach a height and spread of 4 feet within 3 years of planting. All shrubs must be a minimum of 18 inches tall when planted.

6. Buffer Strip Options

One of the following buffer strip options is required along a perimeter lot line that abuts a protected district.

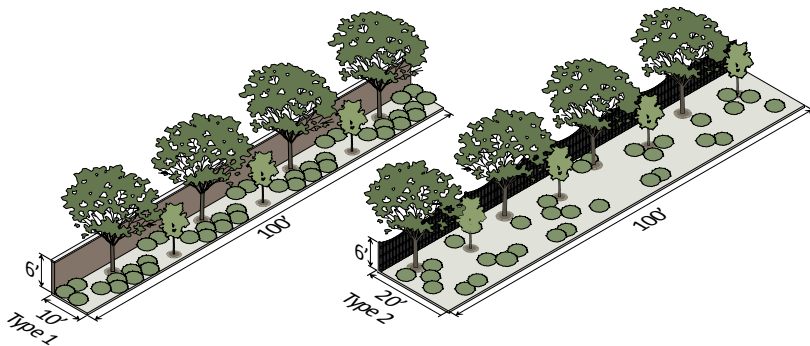

	Type 1	Type 2
Depth (min)	10'	20'
Wall Height (min/max)	6'/8'	6'/8'
Fence Height (min/max)	Not allowed	6'/8'
Shade Trees (min per 100')	4	4
Understory Trees (min per 100')	3	4
Shrubs (min per 100')	40	30
Shrub Height (min)	4'	4'

C. Screening

1. Service Areas

- a. Trash collection, trash compaction, recycling collection and other similar service areas must be located to the side or rear of buildings and must be within a fully screened enclosure as described below.
- b. Service areas that are fully integrated into a building must be within an enclosure closed by a solid roll down door or gate.
- c. Service areas that are not integrated into a building must be screened on 3 sides by a wall constructed of complimentary material as the primary structure and at least 7 feet in height; the service opening on the fourth side must be screened by a solid metal gate at least 7 feet in height.
- d. The service enclosure must be maintained in good working order and must remain closed except when trash pick-up occurs.

2. Roof-Mounted Equipment

- a. Roof-mounted equipment must be screened from ground level view from adjacent property or adjacent public street right-of-way (not including an alley).
- b. New buildings must provide a parapet wall or other architectural element that screens roof-mounted equipment from ground level view.

3. Wall-Mounted Equipment

- a. Wall-mounted equipment cannot be located on any surface that directly faces a public right-of-way (not including an alley).
- b. Wall-mounted equipment located on any surface that is visible from a public right-of-way (not including an alley) must be fully screened by landscaping or an opaque screen.

4. Ground-Mounted Equipment

Ground-mounted mechanical equipment that is visible from a public right-of-way (not including an alley) must be screened from view by landscaping or a wall. The screening must be of a height equal to or greater than the height of the mechanical equipment being screened.

D. Fences and Walls

Walls and fences not within a buffer strip must be designed to comply with the following standards:

1. Fences and walls may be placed up to the property line and any posts or supporting rails must face inward toward the property being fenced.
2. A wall or fence located in a primary or side street setback, not used for a required screen, cannot be more than 6 feet height. The opacity of the wall or fence above 4 feet in height must exceed 50%.
3. A wall or fence located in a side or rear setback cannot be more than 8 feet in height.
4. Walls must be constructed of high quality materials including one or a combination of the following: decorative blocks; brick; stone; cast-stone; split-faced block; stucco over standard concrete masonry blocks; glass block; or other material approved by the Midtown Development Review Committee.
5. No wall containing more than 50% exposed standard concrete masonry blocks are allowed, whether painted or not.
6. Fences must be constructed of high quality materials including one or a combination of the following: wood, composite fencing; wrought iron or other material approved by the Midtown Development Review Committee.
7. No wall or fence may be located within any required drainage or utility easement.
8. Barbed wire or concertina wire is not allowed.
9. Chain-link fences are not allowed in any primary or side street setback.

E. Parking Lot Landscaping

All on-site surface parking lots with more than 10 spaces must be landscaped as specified in *Sec. 5.1.G. Parking Lot Landscaping*.

F. Street Trees

Street trees may also be required to be planted in conformance with *Article 6. Streets*.

G. Plant Installation

1. General Provisions

- a. Plant materials must be hardy to zone 8 in accordance with the U.S. Department of Agriculture's Plant Hardiness Zone Map.
- b. Trees must be a species recognized by the State of Mississippi Division of Forestry, as being acceptable for Midtown.
- c. Plant materials must be able to survive on natural rainfall once established with no loss of health.
- d. Tree height is measured from the top of the root ball to the tip of the main stem.

2. Shade Trees

- a. All shade trees planted to meet the landscaping requirements must be a locally adapted species with an expected mature height of 35 feet or greater and an expected mature crown spread of at least 30 feet or greater unless subject to an overhead power line in which case the mature height may be less.
- b. All shade trees planted to meet the landscaping requirements must have a minimum caliper of 3 inches and be at least 10 feet tall at time of planting.

3. Understory Trees

- a. Understory trees planted to meet the landscaping requirements must be a locally-adapted species with an expected mature height of at least 15 feet and an expected mature crown spread of at least 15 feet.
- b. Single-stem understory trees planted to meet the landscaping requirements must have a minimum caliper of 1½ inches and be at least 6 feet tall at time of planting.
- c. Multi-stem understory trees planted to meet the landscaping requirements must be at least 6 feet tall at time of planting.

H. Maintenance

The owner or tenant is responsible for maintaining all required landscaping in good health and condition. Any dead, unhealthy, deteriorating, broken or missing landscaping must be replaced with landscaping that conforms to this Code within 30 days (or within 180 days where weather concerns would jeopardize the health of plant materials).

I. Visibility at Intersections

Nothing can be erected, placed, planted or allowed to grow in such a manner as to impair or block vision between a height of 2.5 feet and 7 feet above the center line grades of the intersecting streets/driveways in the area bounded by the street lines/driveway lines of the corner and a line joining points along said street lines 30 feet from the point of intersection.

Sec. 5.3. Signs

A. Applicability

1. No sign may be erected, altered, refurbished or otherwise modified after the effective date of this Code except in accordance with the requirements of this section.
2. In addition to the following sign standards, the requirements of Sec. 95. Signs, of the Land Development Code, applies to all signs within the Midtown Form-Based Code District:
 - a. Sec. 95.01, General Description;
 - b. Sec. 95.02, Permit Required for Signs;
 - c. Sec. 95.03, Signs Excluded for Regulation;
 - d. Sec. 95.04, Certain Temporary Signs;
 - e. Sec. 95.05, Determining the Number of Signs;
 - f. Sec. 95.12, Miscellaneous Restrictions and Prohibitions;
 - g. Sec. 95.13, Maintenance of Signs;
 - h. Sec. 95.14, Unlawful Cutting of Trees and Shrubs; and
 - i. Sec. 95.15, Nonconforming Signs.

B. Signs in the Right-of-Way

1. Ground signs and bracket signs cannot encroach into the public right-of way.
2. Wall signs, awning signs, canopy signs, projecting signs, crown signs, shingle signs and sidewalk signs may encroach over the public sidewalk but not over any public street, parking area, driveway or alley. All signs must be a minimum of 18 inches inside the curb line or edge of pavement, whichever is greater.

C. Common Sign Plan

A common sign plan must be approved for sites occupied by more than one tenant or a large complex. All tenant signs must meet the requirements of the common sign plan. The applicant must indicate the standards of consistency of all signs on the property with regard to:

1. Colors;
2. Letter/graphics style;
3. Location of each sign;
4. Materials used in sign construction;
5. Maximum dimensions and proportion; and,
6. Directional signage.



D. Computation of Sign Area

The area of all signs is computed as follows:

1. For signs consisting of freestanding letters or logos, sign area is calculated as the total area of the rectangle, circle or square that fully encloses all the letters or logo.



2. For cabinet signs and signs on a background, the entire area of the background is calculated as sign area, including any material or color forming the sign face and the background used to differentiate the sign from the structure against which it is mounted. Sign area does not include any supports or bracing. The entire ground sign other than the base is considered a background for the purposes of measurement.

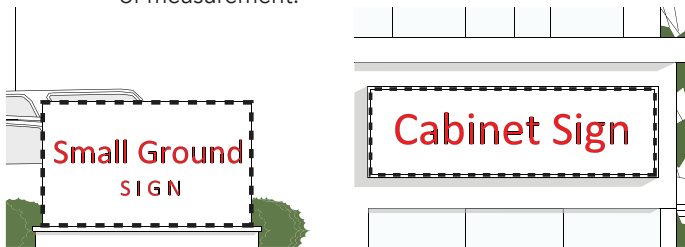

3. The area for a sign with more than one face is computed by adding together the area of all sign faces that are 45 degrees or greater; if the sign face angle is less than 45 degrees only the area of the largest sign face is computed as part of the sign area.

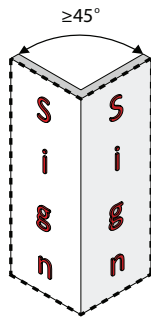

4. The sign area of a three-dimensional sign is calculated as total area of the smallest rectangle, circle or square that fully encloses the largest profile of the three-dimensional sign.

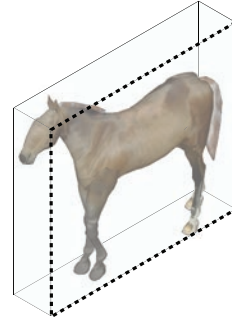

E. Measurement of Sign Height

The total height of a ground or bracket sign is measured from the highest point of the sign or supporting structure to the top of the abutting sidewalk.

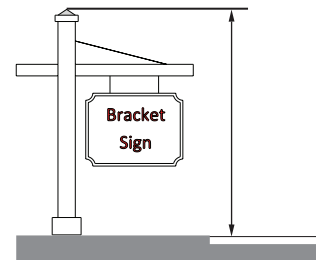

F. Sign Types Allowed by District

Signs are allowed by district as established below. Specific requirements for each sign are shown on the following pages.

	Mixed Use (MX-3, -4, -5)	Employment (EM-2, -3)	Employment (EM-4, -6, -9)	Residential Attached (RA-3)	Residential Detached (RD-2)	Open Space (OS)
Awning Sign	●	●	●			
Bracket Sign	●	●	●	◐		●
Canopy Sign	●	●	●			
Crown Sign	▲		●			
Ground Sign, Small	●	●	●	◐		
Ground Sign, Large	○		●			
Projecting Sign	●	●	●			
Shingle Sign	●	●	●	◐		●
Sidewalk Sign	●					
Wall Sign	●	●	●	◐		
Window Sign	●					

● = Allowed sign type ○ = Allowed on sites with street frontage on US 49
 ▲ = Allowed on building 55 feet and higher ◐ = Allowed for permitted non-residential uses

G. Allocation of Sign Area

The maximum sign area for each sign type is determined by the district and is established below. For each cell in the table there is a maximum allowed sign area that may be utilized with any combination and any number of signs associated with that cell, unless otherwise noted. See Sec. 5.3.H thru See Sec. 5.3.R. for additional sign standards by type of sign.

	Mixed Use (MX-3, -4, -5)	Employment (EM-2, -3)	Employment (EM-4, -6, -9)	Residential Attached (RA-3)	Residential Detached (RD-2)	Open Space (OS)
Awning Sign				--	--	--
Canopy Sign				--	--	--
Projecting Sign	1 sf/ft bldg width	1 sf/ft bldg width	1 sf/ft bldg width	--	--	--
Wall Sign				.5 sf/ft bldg width	--	--
Bracket Sign	9 SF	9 SF	9 SF	9 SF		9 SF
Crown Sign	250 SF	--	250 SF	--	--	--
Ground Sign, Small	32 SF	32 SF	32 SF	16 SF	--	--
Ground Sign, Large	64 SF	--	64 SF	--	--	--
Shingle Sign	9 SF	9 SF	9 SF	9 SF	--	9 SF
Sidewalk Sign	6 SF	--	--	--	--	--
Window Sign	20%	--	--	--	--	--

ft of building width = width of building facade facing street

H. Awning Sign



Description

A sign where graphics or symbols are painted, sewn or otherwise adhered to the awning material as an integrated part of the awning itself.

General Provisions

1. An awning sign cannot extend outside the awning.
2. Only awnings over first and second story doors and windows may contain signs.
3. A maximum of 1 sign is allowed per awning face.
4. An awning sign may only be externally illuminated under Sec. 5.3.5.

Standards

(A) Overall area allocation (max)	Sec. 5.3.G
(B) Width (max % of awning width/depth)	75%
(C) Height of text and graphics on valance (max)	2'
(D) Area of sloping plane covered by sign (max)	25%
(E) Clear height above sidewalk (min)	12'

I. Bracket Sign

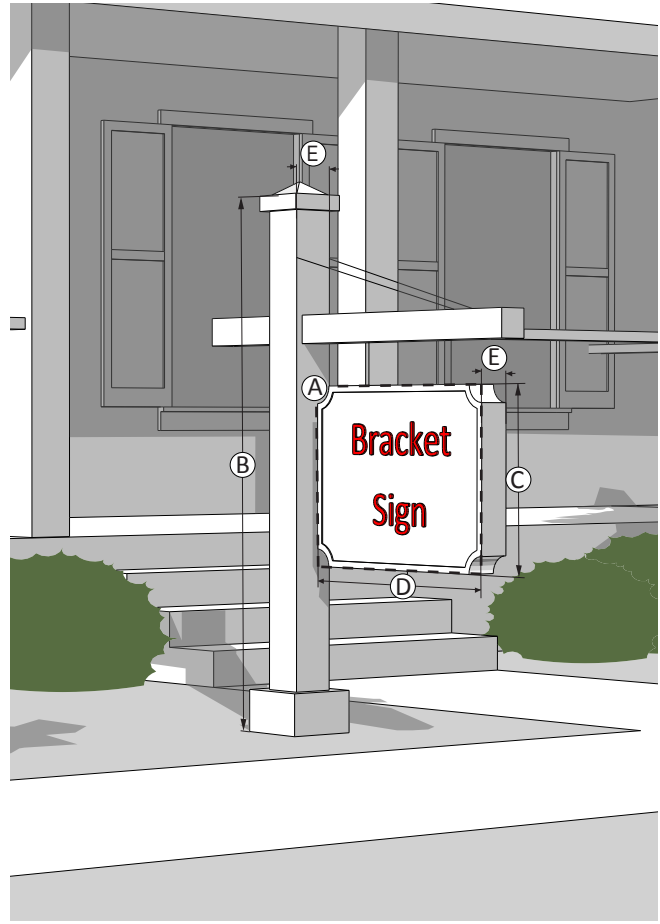

Description	
A sign attached to the ground by one or more support structures that is not higher than 5 feet and hangs from a bracket or support.	
General Provisions	
1.	Only 1 bracket sign is allowed per building.
2.	A bracket sign must be located at least 25 feet from any other bracket sign.
3.	The hanging bracket must be an integral part of the sign design.
4.	A bracket sign can only be externally illuminated in accordance with Sec. 5.3.S.

Standards	
(A)	Sign area (max per sign) 9 SF
(B)	Structure height (max) 5'
(C)	Sign height (max) 3'
(D)	Sign width (max) 3'
(E)	Structure/sign depth (max) 6"

J. Canopy Sign



Description

A sign placed on a canopy so that the display surface is parallel to the plane of the wall.

General Provisions

1. A canopy sign cannot extend outside the overall length or width of the canopy. However, a canopy sign may extend above or below the canopy.
2. A maximum of 1 sign is allowed per canopy.
3. Raceways are permitted for signs extending below or above the canopy. Otherwise, raceways are not permitted and the sign must be flush with the canopy face.
4. A canopy sign can be externally or internally illuminated under Sec. 5.3.5.

Standards

(A)	Overall area allocation (max)	Sec. 5.3.G
(B)	Width (max % of canopy width)	75%
(C)	Height of text and graphics (max)	2'
(D)	Depth (max)	1'
(E)	Raceway (max % of letter height)	50%
(F)	Clear height above sidewalk (min)	12'

K. Crown Sign

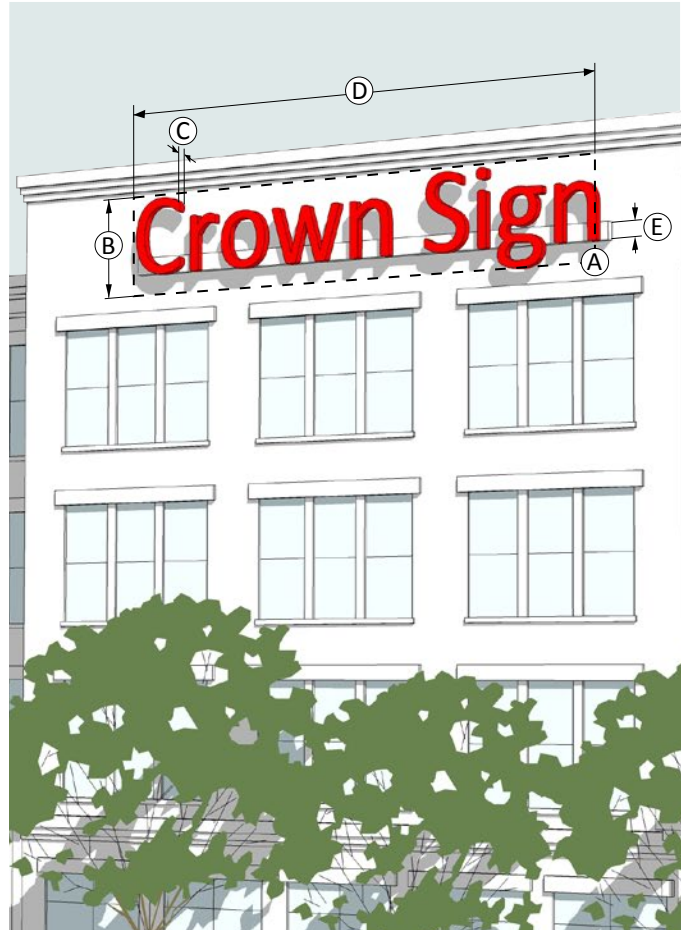

Description

A wall sign extending not more than 3 feet from the building facade located on the upper horizontal band of a building at least 55 feet in height.

General Provisions

1. A crown sign is only allowed on buildings greater than 55 feet in height.
2. A crown sign cannot be placed below the start of highest floor and cannot extend above the roof line.
3. A crown sign cannot cover windows or architectural details.
4. No more than 1 crown sign per building facade and no more than 2 crown signs per building are allowed.
5. A crown sign can only be internally illuminated in accordance with Sec. 5.3.S.

Standards

(A) Sign area (max per sign)	250 SF
(B) Height (max)	8'
(C) Projection - measured from building facade (max)	3'
(D) Width (max % of facade width)	75%
(E) Raceway (max % of letter height)	25%

L. Ground Sign, Small



Description

A sign attached along its entire width to a continuous pedestal that is no higher than 5 feet. A small ground sign is horizontally oriented or is square.

General Provisions

1. One ground sign (small or large) is allowed per street frontage, except that 1 additional ground sign is allowed for properties with 200 feet or more of street frontage. Where more than 1 ground sign is permitted, signs along the same street frontage must be spaced a minimum of 150 feet apart.
2. A small ground sign must be set back at least 5 feet from the front property line and 10 feet from a side property line.
3. A sign erected on a retaining wall is required to meet the standards for a small ground sign. The height of the wall is included in the overall height calculation.
4. A small ground sign can be externally or internally illuminated in accordance with Sec. 5.3.5.

Standards

A Sign area (max per sign)	
MX-3, -4, -5, EM-2, -3, -4, -6, -9	32 SF
RA-3	16 SF
B Height (max)	
	5'
C Depth (max)	
	18"

M. Ground Sign, Large



Description

A sign attached along its entire width to a continuous pedestal that is between 5 and 10 feet in height. A large ground sign is vertically oriented or is square.

General Provisions

1. A large ground sign is only allowed for properties that have street frontage on US 49.
2. One ground sign (large or small) is allowed per street frontage, except that 1 additional ground sign is allowed for properties with 200 feet or more of street frontage. Where more than 1 ground sign is permitted, signs along the same street frontage must be spaced a minimum of 150 feet apart.
3. A large ground sign must be set back at least 10 feet from the front property line and 15 feet from a side property line.
4. A large ground sign can be externally or internally illuminated in accordance with Sec. 5.3.S.

Standards

Ⓐ Sign area (max per sign)	64 SF
Ⓑ Height (max)	10'
Ⓒ Depth (max)	2'

N. Projecting Sign

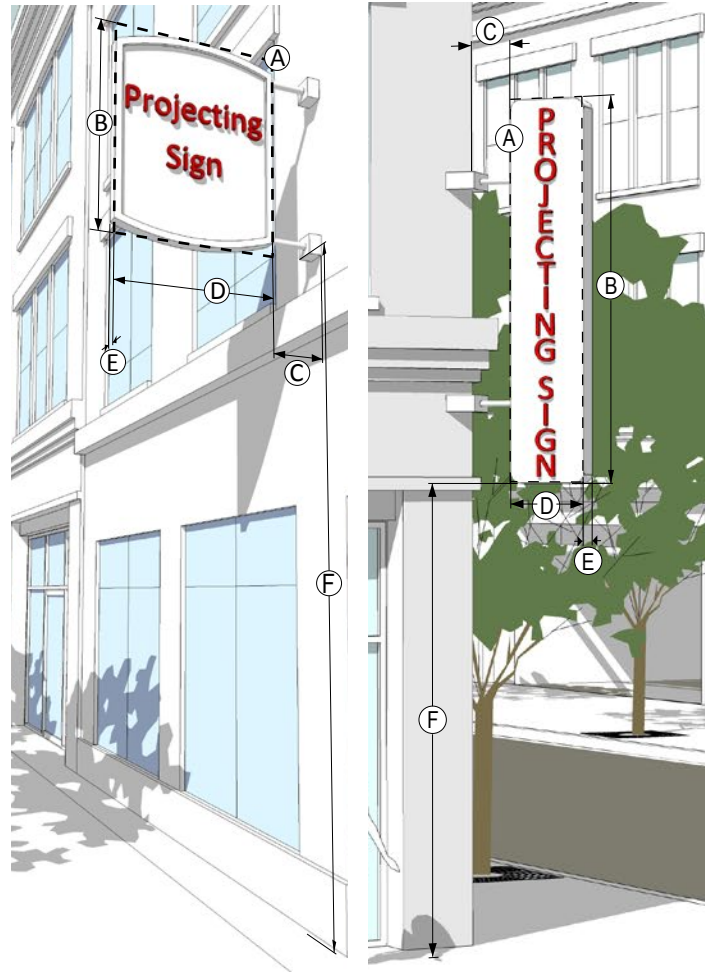

Description

A sign that is wholly or partly dependent upon a building for support, which projects at an angle away from the building, extending more than 1 foot.

General Provisions

1. A projecting sign must be at least 25 feet from any other projecting sign.
2. A projecting sign may be erected on a building corner when the building corner adjoins the intersection of two streets. Allocation of sign area from both streets may be used, however, in no case can the sign exceed the maximum height and width standards.
3. The top of a projecting sign can be no higher than the top of the building. However, on one story buildings, the top of a projecting sign may have a maximum of 20% of the sign height above the top of the building.
4. For buildings four stories and higher, a projecting sign cannot be located above the window sills of the fourth story.
5. A projecting sign can be externally or internally illuminated under Sec. 5.3.S.

Standards

Standard	Requirement
(A)	Overall area allocation (max) Sec. 5.3.G
(B)	Height (max)
	1 story building 4'
	2 story building 8'
	3 or more story building 12'
(C)	Spacing from building facade (min/max) 1'/2'
(D)	Projection width (max) 4'
(E)	Depth (max) 1'
(F)	Clear height above sidewalk (min) 12'

O. Shingle Sign



Description	
A small projecting sign that hangs from a bracket or support and is located over or near a building entrance.	
General Provisions	
1.	A shingle sign must be located within 5 feet of an accessible building entrance.
2.	The hanging bracket must be an integral part of the sign design.
3.	A shingle sign must be located below the window sills of the second story on a multi-story building or below the roof line on a single-story building.
4.	A shingle sign cannot be illuminated.

Standards	
(A)	Sign area (max per sign) 9 SF
(B)	Height (max) 3'
(C)	Spacing from building facade (min) 6"/12"
(D)	Projection width (max) 3'
(E)	Depth (max) 6"
(F)	Clear height above sidewalk (min) 12'

P. Sidewalk Sign



Description

A moveable sign not secured or attached to the ground or surface upon which it is located.

General Provisions

1. Each ground floor tenant can have 1 sidewalk sign that must be located adjacent to the primary facade with the principal customer entrance, but cannot be placed more than 8 feet from that facade.
2. A sidewalk sign must be located at least 25 feet from any other sidewalk sign.
3. Sidewalk signs must be removed and placed indoors at the close of business each day.
4. Sidewalk signs cannot obstruct vehicular, bicycle or pedestrian traffic and must comply with ADA clearance and accessibility.
5. A sidewalk sign cannot be illuminated.

Standards

Ⓐ	Sign area (max per sign)	6 SF
Ⓑ	Height (max)	3'
Ⓒ	Width (max)	2'

Q. Wall Sign

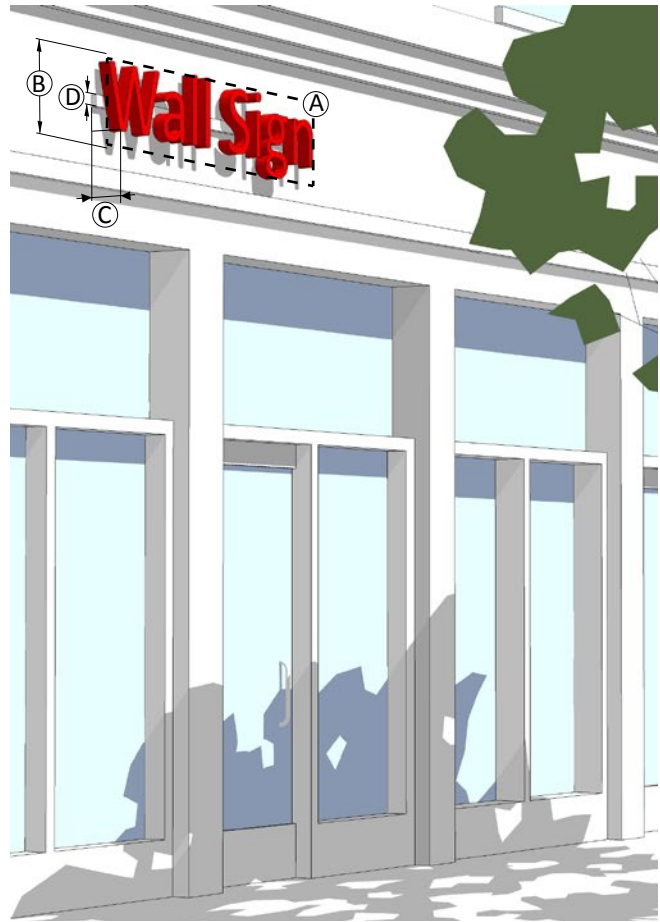

Description

A sign fastened to or painted on the wall of a building in such a manner that the wall becomes the supporting structure for or forms the background surface of the sign and which does not project more than 1 foot from the building or structure.

General Provisions

1. A wall sign must be placed no higher than 18 feet above the sidewalk.
2. No portion of a wall sign may extend above the roof line or above a parapet wall of a building with a flat roof.
3. No portion of a wall sign may extend above the lower eave line of a building with a pitched roof.
4. A wall sign cannot cover windows or architectural details.
5. A wall sign can be externally or internally illuminated under Sec. 5.3.S.

Standards

(A) Overall area allocation (max)	Sec. 5.3.G
Sign area (max per sign)	60 SF
(B) Height (max)	5'
(C) Projection - measured from building facade (max)	1'
(D) Raceway (max % of letter height)	50%

R. Window Sign



Description

A sign affixed to the inside of a window or door or a sign placed within a building so as to be plainly visible and legible through a window or door.

General Provisions

1. Window signs are only allowed on ground story windows and doors.
2. A window sign can only be internally illuminated in accordance with Sec. 5.3.S.

Standards

(A) Area of all ground story windows and doors covered by signs (max combination of all windows and doors covered by window signs)	20%
--	-----

S. Sign illumination

Illumination of signs must be in accordance with the following requirements:

1. General Requirements

- a. No sign within 50 feet of a protected district may be illuminated between 11 p.m. and 6 a.m.
- b. Strings of lights that outline property lines, sales areas, roof lines, doors, windows or similar area are prohibited, except for temporary lighting erected in connection with observed holidays.

2. External Illumination

- a. Lighting directed toward a sign must be shielded so that it illuminates only the face of the sign and does not shine directly into a public right-of-way or onto adjacent properties.
- b. Projecting light fixtures used for externally illuminated signs must be simple and unobtrusive in appearance and not obscure the sign.

3. Internal Illumination

- a. Channel letters may be internally lit or back-lit.
- b. The background of cabinet signs must be opaque or a darker color than the message of the sign.
- c. Exposed neon may be used for lettering or as building accent.

4. Prohibited Light Sources

The following light sources are not allowed:

- a. Blinking, flashing and chasing; and
- b. Bare bulb illumination.

5. Raceways and Transformers

- a. If a raceway is necessary, it cannot extend in width or height beyond the area of the sign.
- b. A raceway must be finished to match the background wall or canopy or integrated into the overall design of the sign.
- c. Visible transformers are not allowed.

6. Electronic Message Board Signs

An electronic message board sign may be allowed for properties that have street frontage on US 49 upon approval by the Midtown Development Review Committee.



External light sources



Internally lit channel letters



Back lit channel letters



Internally lit cabinet signs with darker background

Sec. 5.4. Site Lighting

A. Applicability

1. General

- a. No permit for the construction, reconstruction, extension or alteration of any building, structure or use of land and no building or land, or any part of any building or land, may be occupied or used until lighting has been provided in accordance with the requirements of this Code.
- b. The installation of site lighting, replacement of site lighting and changes to existing light fixture wattage, type of fixture, mounting or fixture location must be made in compliance with this Code. Routine maintenance, including changing the lamp, ballast, starter, photo control, fixture housing, lens and other required components, is allowed for all existing fixtures.
- c. This section does not apply to lighting installed in the public right-of-way.

2. Additions

- a. When a building or site is renovated, any new or replaced outdoor light or lighting fixture must conform to the requirements of this Code.
- b. When the gross floor area or improved site area is increased, the additional floor or site area must conform to the lighting requirements of this Code.
- c. When the gross floor area or improved site area is increased by more than 50% cumulatively, both the existing use and the additional floor or site area must conform to the lighting requirements of this Code.

3. Change in Use

A change in use does not trigger application of this section

B. Light Level Measuring

1. Light levels are specified, calculated and measured in footcandles. All footcandles values are maintained footcandles.

2. Measurements are to be made at ground level, with the light-registering portion of the meter held parallel to the ground pointing up.

C. Prohibited Sources

The following light fixtures and sources cannot be used:

1. Cobra-head-type fixtures having dished or drop lenses or refractors, which contain sources that are not incandescent;
2. Temporary searchlights and other high-intensity narrow-beam fixtures; and
3. Light sources that lack color correction or do not allow for uniform site lighting.

D. Design and Installation Requirements

1. The maximum light level of any light fixture cannot exceed 0.5 footcandles measured at the property line of any protected district or RA-3 or RD-2 district and 2.0 footcandles measured at the right-of-way line of a street.
2. Lighting must not be oriented onto adjacent properties, streets or sidewalks.
3. Service connections for all freestanding lighting fixtures must be installed underground.

E. Parking and Pedestrian Areas

1. Light fixtures within parking and vehicular display areas may be no higher than 30 feet.
2. Light fixtures within pedestrian areas may be no higher than 15 feet.

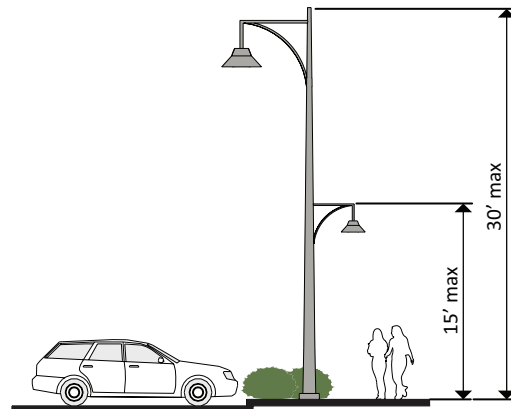

- Light fixtures located within 50 feet of the property line of a protected district may be no higher than 15 feet.
- Light fixtures within 25 feet of a street right-of-way (not including an alley) must be forward throw fixtures.
- All light fixtures must be full cutoff, except as listed in paragraph 6. below.

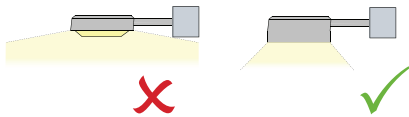

- Non-cutoff (unshielded) fixtures can be used when the maximum initial lumens generated by each fixture is less than 9,500 initial lamp lumens. These fixtures generally feature globes or vertical glass planes and must be coated with an internal white frosting to diffuse light.

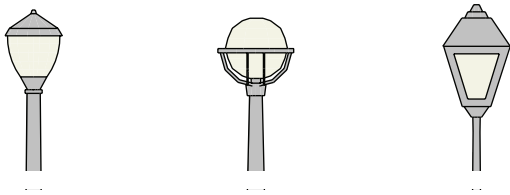

F. Flood Lights and Flood Lamps

- Flood light fixtures must either be aimed down at least 45 degrees from vertical or the front of the fixture shielded so that no portion of the light bulb extends below the bottom edge of the shield.

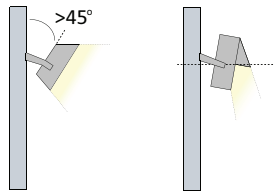

- Any flood light fixture located within 50 feet of a street right-of-way must be mounted and aimed perpendicular to the right-of-way, with a side-to-side horizontal aiming tolerance not to exceed 15 degrees.

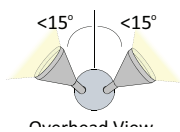

- All flood lamps emitting 1,000 or more lumens must be aimed at least 60 degrees down from horizontal or shielded so that the main beam is not visible from adjacent properties or the street right-of-way.

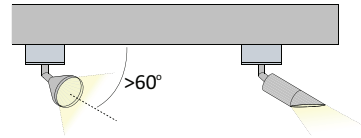

G. Vehicular Canopies

Lighting under vehicular canopies must be less than 24 maintained footcandles and be designed to prevent glare off-site. Acceptable lighting designs include the following:

- Recessed fixture incorporating a lens cover that is either recessed or flush with the bottom surface of the canopy;

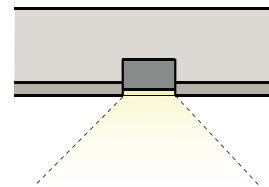

- Light fixture incorporating shields or is shielded by the edge of the canopy itself, so that light is restrained to 5 degrees or more below the horizontal plane;

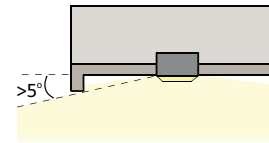

- Surface mounted fixture incorporating a flat glass that provides a cutoff design or shielded light distribution; or

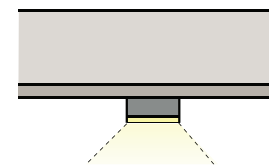

4. Indirect lighting where light is beamed upward and then reflected down from the underside of the canopy, provided the fixture is shielded so that direct illumination is focused exclusively on the underside of the canopy.

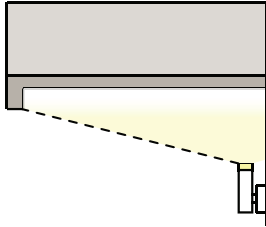

H. Building Lighting

1. Lighting fixtures must be selected, located, aimed and shielded so that direct illumination is focused exclusively on the building facade, plantings and other intended site features and away from adjoining properties and the street right-of-way.
2. All wall pack fixtures must be full cutoff fixtures.



3. Only lighting used to accent architectural features, landscaping or art may be directed upward, provided that the fixture is located, aimed or shielded to minimize light spill into the night sky.

Sec. 5.5. Outdoor Display and Storage

A. Applicability

The requirements of this section apply to any lot where merchandise, material or equipment is stored outside of a completely enclosed building.

B. Outdoor Display

1. Defined

- a. Outdoor display is the outdoor display of products actively available for sale that is placed in a fully-enclosed building at the end of each business day.
- b. Outdoor display does not include merchandise or material in boxes, in crates, on pallets or other kinds of shipping containers, propane gas storage racks, ice storage bins, soft drink or similar vending machines (see outdoor storage).

2. Standards

Outdoor display is permitted in association with any permitted non-residential principal ground floor use in accordance with the following provisions:

- a. Outdoor display must be removed and placed inside a fully-enclosed building at the end of each business day.
- b. Outdoor display is permitted adjacent to the primary facade with the principal customer entrance, but cannot extend more than 8 feet from the facade and occupy no more than 30% of the horizontal width of the facade.
- c. Outdoor display cannot impair the ability of pedestrians to use the sidewalk or parking areas and must comply with ADA clearance and accessibility.

C. Outdoor Storage

1. Defined

- a. Outdoor storage is the overnight storage of products or materials outside of a building.
- b. Outdoor storage includes merchandise or material in boxes, in crates, on pallets or in shipping containers, propane gas storage racks, ice storage bins, soft drink or similar vending machines.

- c. Outdoor storage includes the overnight outdoor storage of vehicles awaiting repair, RVs and boats, garden supplies, building supplies, plants, fleet vehicles and other similar merchandise, material, vehicles or equipment.
- d. Outdoor storage also includes salvage yards, vehicle storage yards; and overnight outdoor storage of shipping containers, lumber, pipe, steel, junk and other similar merchandise, material or equipment.

2. Standards

- a. Outdoor storage is not permitted in the Midtown Form-Based Code District, except when approved by the Midtown Development Review Committee.
- b. The Midtown Development Review Committee will determine where outdoor storage may be allowed on the site and its extent (vertically and horizontally) must be shown on the site plan.

Page Intentionally Left Blank

Article 6. Streets

Sec. 6.1. General Provisions

A. Applicability

This Article provides guidelines for the construction of new streets and reconstruction of existing streets and is intended to provide a catalog of pre-approved street types. Additional street types may be approved by the City Engineer.

B. Future Street Map

The Future Street Map identifies the type and alignment of future streets and street connections in the Midtown Form-Based Code District.

1. New Streets

Where a new street needs to be constructed as shown on the Future Street Map, the street must be constructed in conformance with this Article, unless an alternative alignment or connection is approved by the City Engineer.

2. Existing Streets

- a. Where an existing street needs to be substantially rebuilt due to an increase in the scale and intensity of development, as determined by the City Engineer, the street must be rebuilt in conformance with this Article.
- b. If an existing street does not need to be substantially rebuilt, as determined by the City Engineer and the sidewalk and street trees do not exist or do not meet the minimum requirements of the applicable street cross-section, sidewalk and street trees must be installed in conformance with this Article.

C. Required Elements

All streets must be constructed with sidewalks, street trees, bike facilities, medians, travel lanes and on-street parking as illustrated for each specific street type, unless an alternative is approved by the City Engineer.

D. Certificate of Occupancy Required

1. Streets, bike facilities, sidewalks and street trees must be installed prior to the issuance of a certificate of occupancy.

2. A temporary certificate of occupancy may be issued when the City Arborist determines that due to the unavailability of plant material or weather concerns that planting of the street trees would jeopardize the health of the trees.

E. Tree Planting

1. Unless otherwise noted below, all trees planted in accordance with this section must be shade trees, planted every 30 feet on center, on average.
2. Where overhead utilities exist, 1 understory tree may be planted every 20 feet on center, on average.
3. All required landscaping must meet the maintenance, installation and intersection visibility requirements of *Sec. 5.2. Landscaping and Screening*.

F. Easements

1. The required sidewalk may be wholly or partially located on private property provided the sidewalk is located within an easement permanently dedicated to the City.
2. The dedicated easement must provide the City with perpetual access to allow for customary public use, including but not limited to, the provision of public signs, street lighting, parking meters and public utilities.
3. The easement cannot be used for underground structures of any kind except those associated with underground utilities.

Sec. 6.2. Midtown Future Street Map

The following map is established and made a part of the City of Hattiesburg Official Zoning Map.

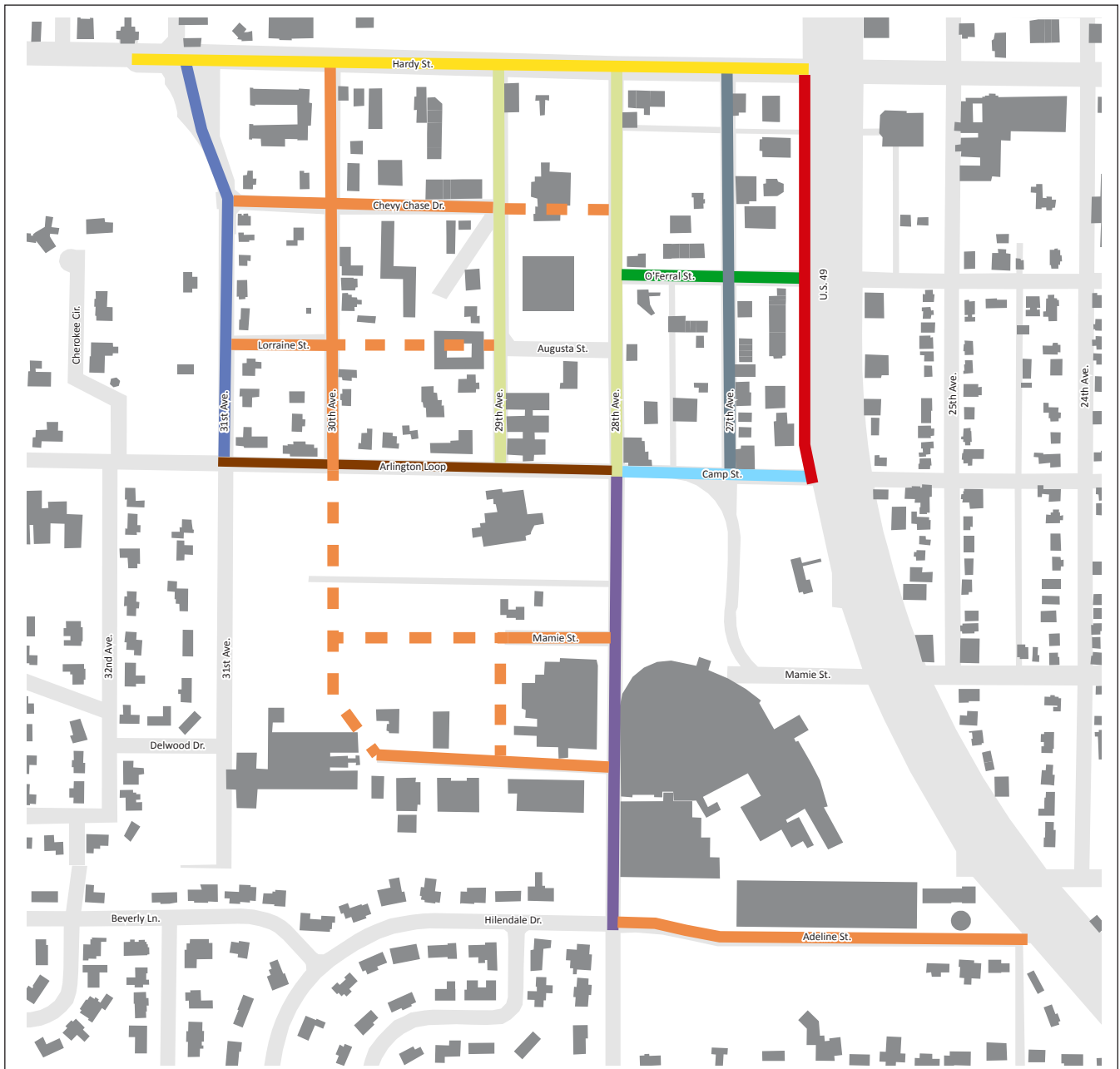

KEY

- | | |
|---|--|
| █ Hardy Street | █ Midtown Local |
| █ Highway 49 | - - - Proposed |
| █ Arlington Loop - East | █ 31st Avenue |
| █ Arlington Loop - West | █ O'Ferral Street |
| █ 29th Ave./28th Ave. - North | █ 27th Avenue |
| █ 28th Avenue - South | |

Sec. 6.3. Street Types

The dimensional and installation requirements for the street types identified on the Midtown Future Street Map are shown on the following pages.

A. Hardy Street

Hardy Street [looking East]

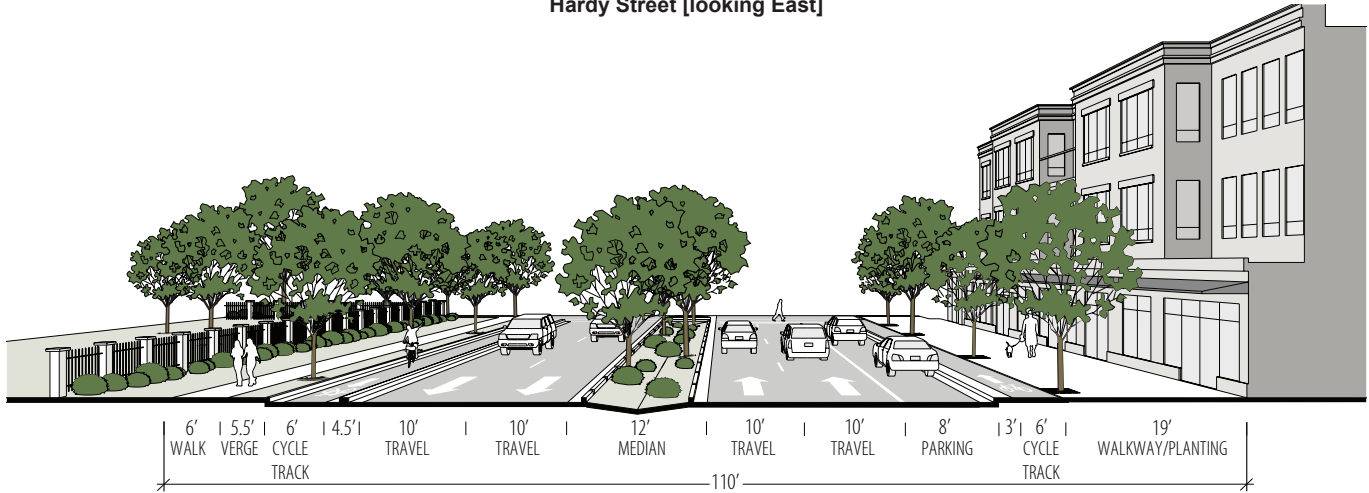

B. US 49

US 49 [looking South]

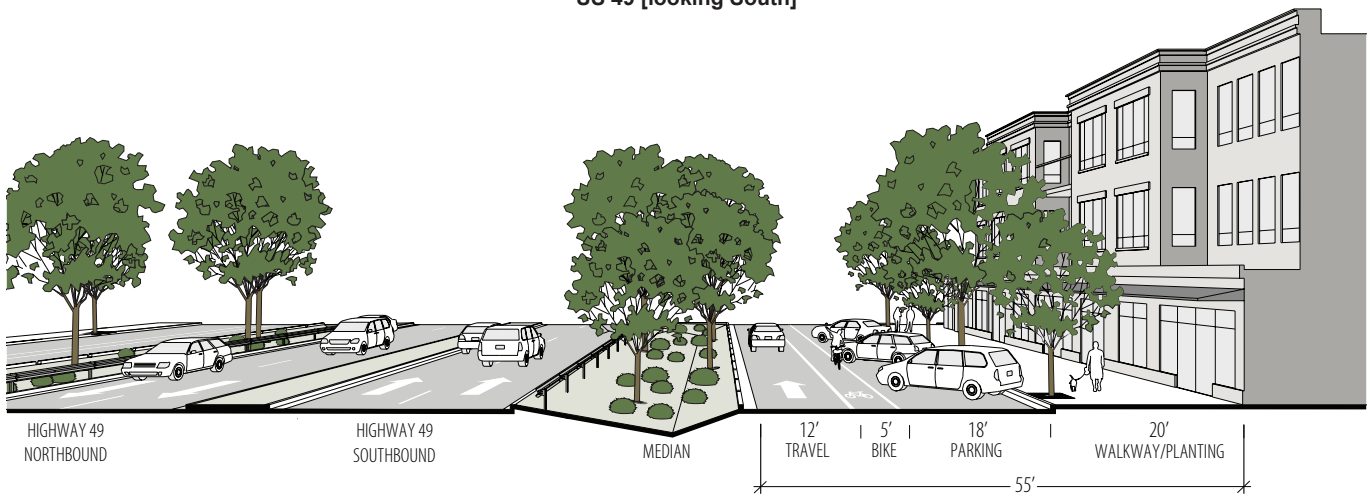

C. Arlington Loop (East of 28th Ave)

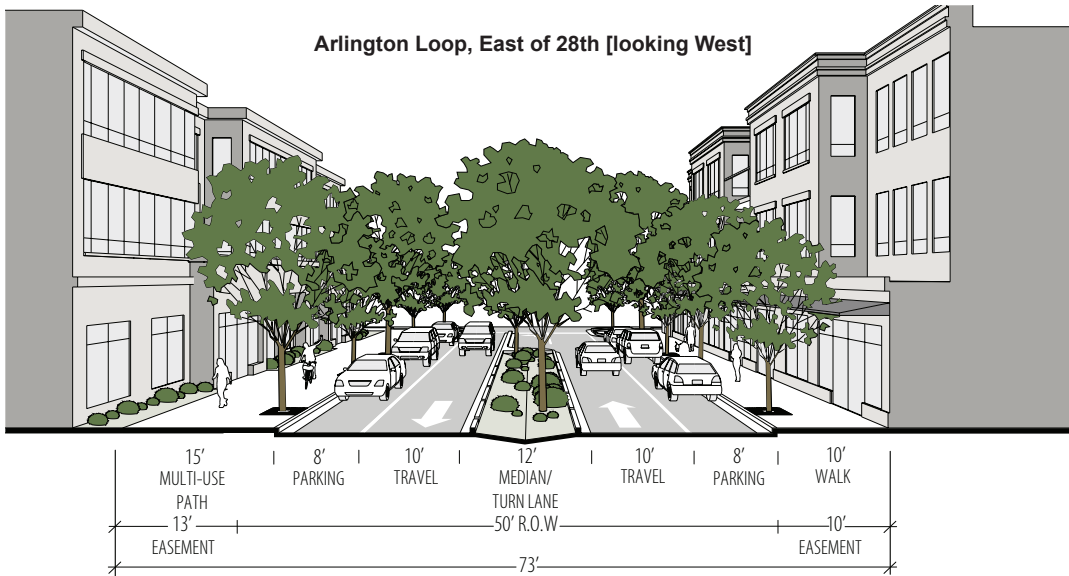

D. Arlington Loop (West of 28th Ave)

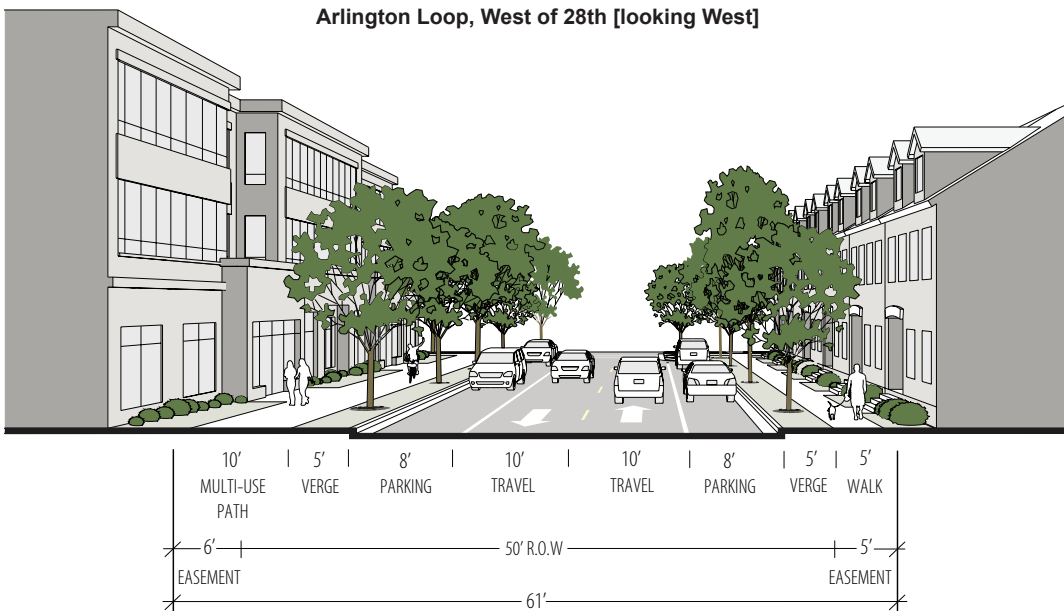

E. 28th/29th Avenue (North of Arlington Loop)

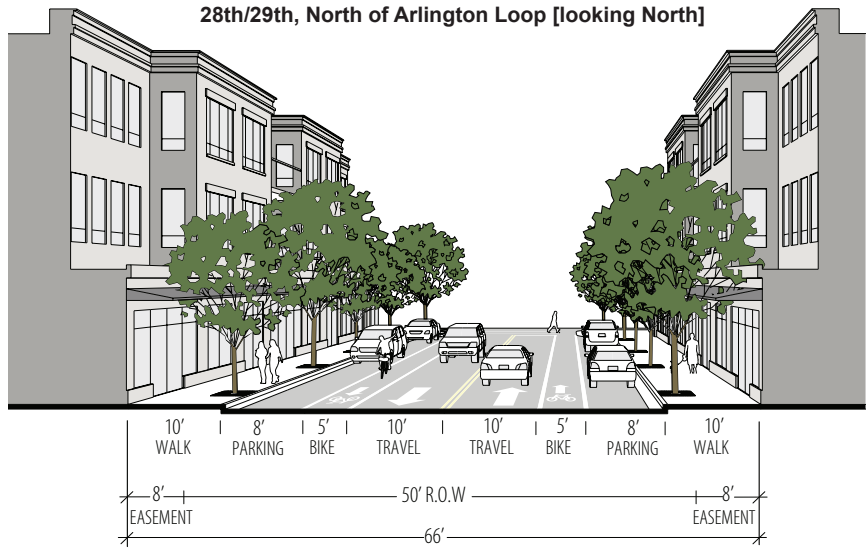

F. 28th Avenue (South of Arlington Loop)

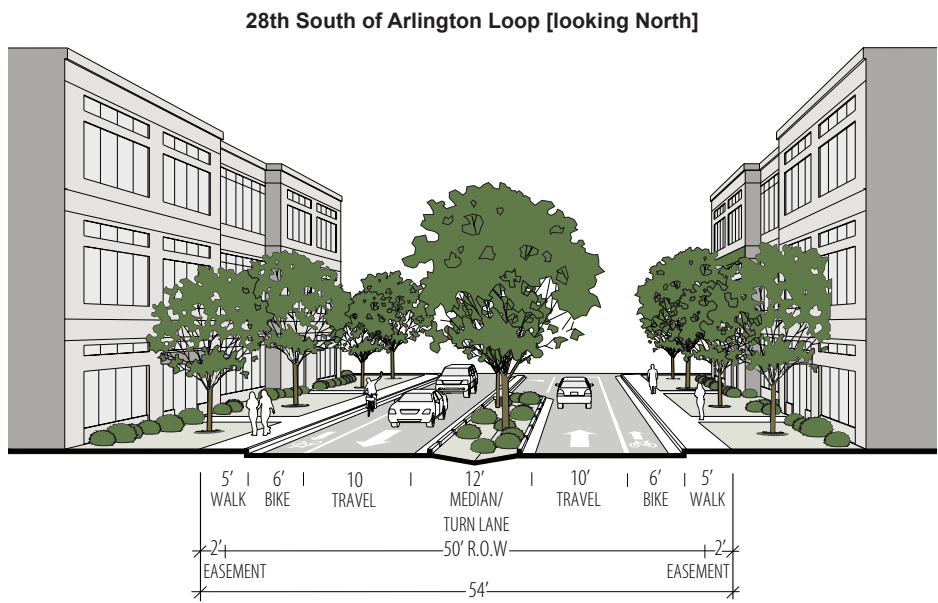

G. 31st Avenue (North of Arlington Loop)

31st [looking South]

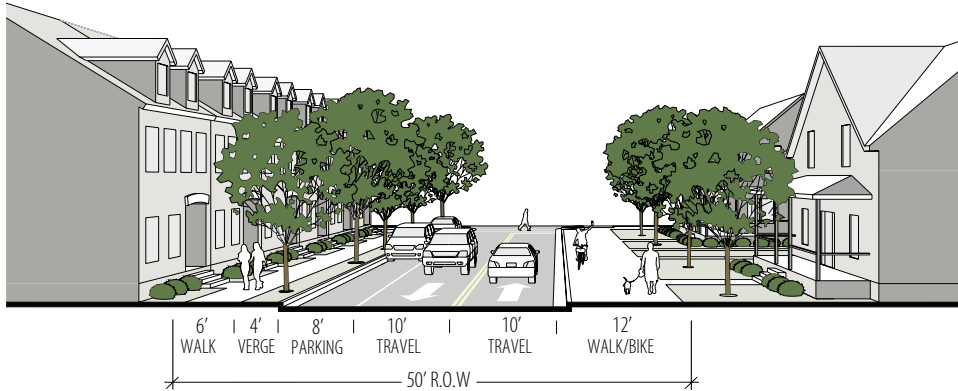

H. O'Ferral Street

O'Ferral [looking West]



I. 27th Avenue

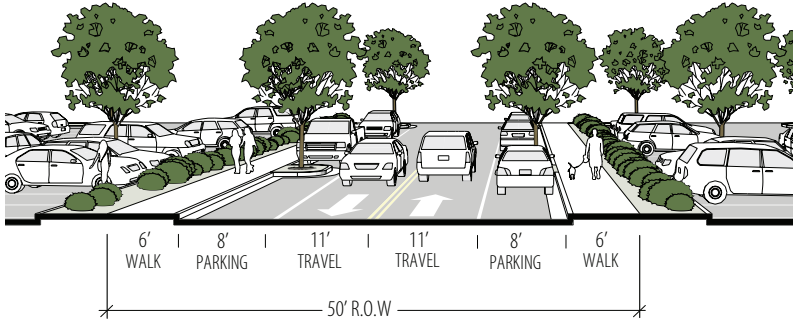

J. Midtown Local

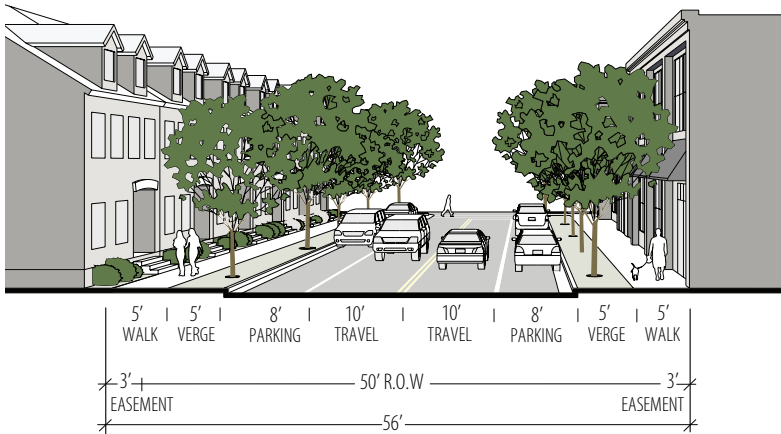

Article 7. Administration

Sec. 7.1. Midtown Development Review Committee

- A. The Midtown Development Review Committee is designated as the Committee whose purpose and responsibility as related to the Midtown Form-Based Code is to utilize to the fullest extent possible its individual and collective technical expertise, to coordinate and expedite the review, processing, recommendation and pre-hearing procedures.
- B. The Midtown Development Review Committee is chaired by the Urban Development Director and consists of the following members or their designated representatives:
 1. City Planning Administrator;
 2. City Engineer;
 3. Fire Marshall;
 4. Building Official;
 5. County Planner; and
 6. Midtown Steering Committee appointees.
- C. The Midtown Development Review Committee is required, as stated by the provisions of this Code, to ensure compliance with the Midtown Form-Based Code and other ordinances as they apply;
 1. To expedite procedures necessary for the obtaining of building permits;
 2. To provide applicants with one central review of their application;
 3. To conserve the time and efforts of applicant and the Midtown Development Review Committee; and
 4. To provide for a speedy processing of applications for building permits.
- D. A review fee will be charged in accordance with the adopted fee schedule.
- E. All procedures for permits, amendments and variances must follow the applicable requirements and procedures as established by City codes or ordinances. See Section 37, Application Procedure. The Midtown Development Review Committee's report must consist of the review of each member.

Sec. 7.2. Deviations from the Code

A. Authority

During the Site Plan Review process, the Midtown Development Review Committee is authorized to approve deviations to certain provisions of this Code, where, due to special conditions, strict enforcement would be physically impractical. This optional process may occur only where the applicant requests a deviation to a standard as specified below.

B. Permitted Deviations

The Midtown Development Review Committee must review the request in light of the purpose and intent of this Code. The Midtown Development Review Committee is authorized to approve a deviation for the following:

1. Build-to Zone (BTZ)

- a. Increase or reduction of up to 20% of the minimum or maximum required primary street or side street setback.
- b. Reduction of up to 5% of the minimum required build-to percentage.

2. Ground Floor Elevation

Reduction of up to 1' of the minimum required ground floor elevation.

3. Story Height

Reduction of up to 10% of the minimum required ground and upper story floor heights.

4. Transparency

Reduction of up to 5% of the minimum percentage of windows and doors that must cover street-facing building facades.

5. Blank Wall Area

Reduction of up to 15% of the maximum allowed blank wall area on street-facing building facades.

6. Pedestrian Access

Reduction of up to 10% of the minimum required distance between street-facing entrances.

7. Alternate Materials

Alternate building and fence and wall materials. Alternate materials must be considered equivalent or better than the materials listed and regionally-available materials are preferred.

8. Parking

Reduction of 10% of the minimum required vehicle parking spaces may be approved by the Midtown Development Review Committee, on a case-by-case basis, based on applicant-submitted parking data that illustrates that the required parking ratios do not accurately apply to their specific development or on the basis of transit service, shared parking or transportation demand management measures.

C. Unlisted Standards

Any request for relief from a required standard, other than those listed above, must be reviewed pursuant to the procedures contained in the Land Development Code, Sec. 40 Variances.

Sec. 7.3. Nonconformities**A. Purpose**

1. The purpose of this section is to establish regulations and limitations on the continued existence of uses, buildings and structures established prior to the effective date of the Midtown Form-Based Code that do not conform to the provisions of this Code.
2. The lawful use of land, buildings and structures existing at the time of passage of this Code may be continued. The provisions of this section are designed to limit reinvestment in uses, buildings and structures that do not conform to this Code and where appropriate, to bring about their eventual compliance in order to preserve the integrity of the regulations established in this Code.

B. Nonconforming Uses**1. Authority to Continue**

Any existing use that does not conform to this Code may be continued as long as it remains otherwise lawful, subject to the provisions below.

2. Ordinary Repair and Maintenance

Any existing use that does not conform to this Code, may undergo normal repair and maintenance or replacement and installation or relocation of non-bearing walls, non-bearing partitions, fixtures, wiring or plumbing.

3. Extensions/Expansions

Any existing use that does not conform with this Code cannot be expanded, enlarged or increased in size, footprint or coverage without approval by the Planning Commission.

4. Change in Use

Any existing use that does not conform to this Code may be changed to a more conforming use with the approval of the Urban Development Director. If changed to a more conforming use it may not be changed back to a less conforming use.

5. Discontinuance

- a. When land used for a nonconforming use ceases to be used for the nonconforming use for 30 consecutive days, the use may not be reestablished or resumed.
- b. When a building containing a nonconforming use ceases to be used for the nonconforming use for 180 consecutive days, the use may not be reestablished or resumed.
- c. Upon evidence of hardship, the Urban Development Director may extend the above time limits once, not to exceed an additional 30 or 180 consecutive days, as applicable.

6. Damage or Destruction

- a. In the event that any building or structure that is devoted in whole or in part to a nonconforming use is damaged or destroyed, by 50% or more of the fair market value of the building or structure immediately prior to the damage, the use cannot be restored.
- b. When a building or structure devoted in whole or in part to a nonconforming use is damaged or destroyed, by less than 50% of the fair market value of the building or structure immediately prior to the damage, the use may be restored to the use that existed prior to the damage, provided that a Certificate of Occupancy has been obtained within 12 months of the date of the damage. Upon evidence of hardship, the Urban Development Director may extend the above time limit once, up to a time period of 12 consecutive months.

C. Nonconforming Buildings or Structures

1. Authority to Continue

Any existing building or structure that does not conform to this Code may be continued as long as it remains otherwise lawful, subject to the provisions below

2. Enlargement, Repair, Alterations

Any existing building or structure that does not conform to this Code may be enlarged, maintained, repaired or altered; provided, that no enlargement, maintenance, repair or alteration creates an additional nonconformity or increases the degree of the existing nonconformity of all or any part of the building or structure, except as specified in *Sec. 7.3.D. Nonconforming Build-to Requirement*.

3. Damage or Destruction

- a. When an existing building or structure that does not conform to this Code is damaged or destroyed by 50% or more of the fair market value of the building or structure immediately prior to the damage, the building or structure must conform, in its entirety, to the requirements of this Code.
- b. When an existing building or structure that does not conform to this Code is damaged or destroyed by less than 50% of the fair market value of the building or structure immediately prior to the damage, the building or structure may be repaired and reconstructed as it was before the damage or destruction, provided that the repair or reconstruction is completed within 12 months of the date of the damage. Upon evidence of hardship, the Urban Development Director may extend the above time limit once, up to a time period of 12 consecutive months.

4. Relocation

An existing building or structure that does not conform to this Code cannot be relocated in whole or in part to any other location on the same or any other lot unless the entire building or structure conforms to this Code after being relocated, except as specified in *Sec. 7.3.D. Nonconforming Build-to Requirement*.

D. Nonconforming Build-to Requirement

1. Additions

When an existing building is being expanded and the building doesn't meet the build-to requirement, the following nonconforming provisions apply.

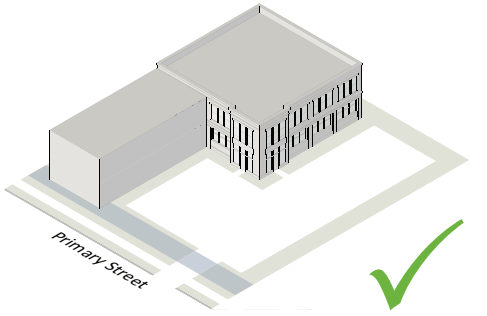

Front Addition. Any addition to the front must be placed in the build-to zone. The addition does not have to meet the build-to percentage for the lot.

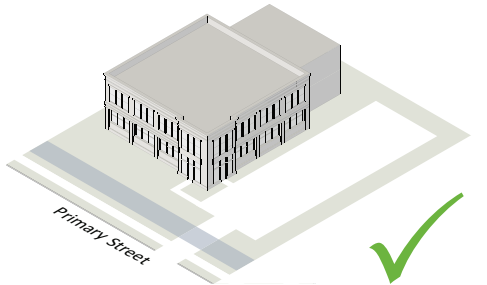

Rear Addition. Rear additions are allowed because the extension does not increase the degree of the nonconformity.

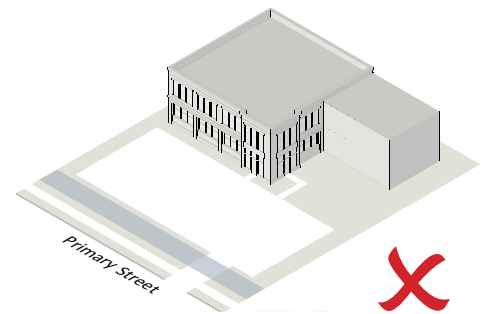

Side Addition. Side additions are not allowed because the extension increases the width of the building not located in the build-to zone.

2. New Buildings

Where a new building is being constructed on a lot or site with an existing building on it that doesn't meet the build-to requirement, the following nonconforming provisions apply.

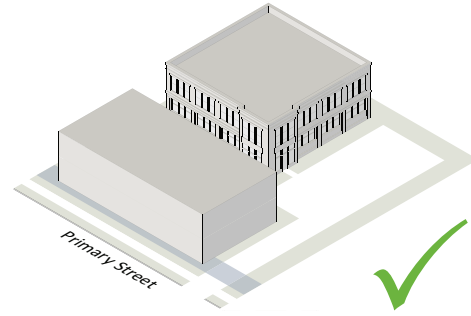

Front New Building. All new buildings must be placed in the build-to zone until the build-to percentage for the lot has been met.

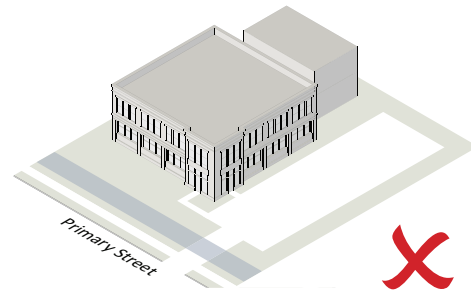

Rear New Building. New buildings located outside of the build-to zone are not allowed until the build-to percentage for the lot has been met.

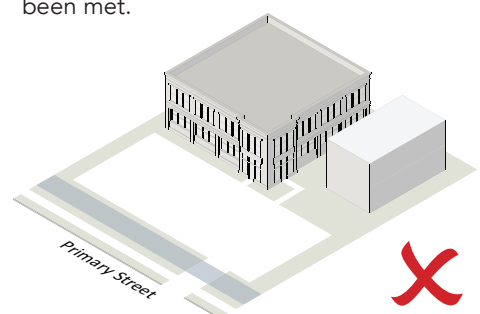

Side New Building. New buildings located outside of the build-to zone are not allowed until the build-to percentage for the lot has been met.

Article 8. Definitions

Sec. 8.1. General Provisions

A. General Meaning of Words and Terms

1. All words and terms used have their commonly accepted and ordinary meaning unless they are specifically defined in this Code or the context in which they are used clearly indicates to the contrary.
2. When vagueness or ambiguity is found to exist as to the meaning of any word or term used, any appropriate canon, maxim, principle or other technical rule of interpretations or construction used by the courts of this state may be employed to resolve vagueness and ambiguity in language.

B. Graphics, Illustrations and Photographs

The graphics, illustrations and photographs used to visually explain certain provisions of this Code are for illustrative purposes only. Where there is a conflict between a graphic, illustration or photograph and the text of this Code, the text controls.

Sec. 8.2. Defined Terms

The following terms are defined for the purpose of this Code. Terms not defined in this Code may be defined in Sec. 5, Definitions, of the Land Development Code. In such case, the definition contained in Sec. 5 of the Land Development Code should be used. If there is a conflict between a definition in Sec. 5 and this Code, the definition in this Code must be used. Definitions for uses are listed in Sec. 4.5. *Use Definitions.*

ABUTTING means having common property lines. Property separated by a street or alley is not considered abutting.

ACTIVE USE means a use other than parking.

ADDITION (to an existing building) means any walled and roofed expansion to the perimeter of a building in which the addition is connected by a common load-bearing wall other than a fire wall. Any walled and roofed addition which is connected by a fire wall or is separated by independent perimeter load-bearing walls is "new construction."

APARTMENT BUILDING means a building type that accommodates 12 or more attached dwelling units vertically and horizontally integrated (see also Sec. 3.1).

APARTMENT COURT means a building type that accommodates 12 or more attached dwelling units vertically and horizontally integrated and organized around a courtyard that fronts a primary street. (see also Sec. 3.1).

ATTIC means habitable or uninhabitable space within a building situated within the structure of a pitched roof and above the uppermost regular story.

AWNING/CANOPY means a wall-mounted, cantilevered structure providing shade and cover from the weather for a sidewalk (see also Sec. 3.16.E).

AWNING SIGN means a sign where graphics or symbols are painted, sewn or otherwise adhered to the awning material as an integrated part of the awning itself (see also Sec. 5.3.H).

BALCONY means a platform projecting from the wall of a building with a railing along its outer edge, often with access from a door or window (see also Sec. 3.16.C).

BLANK WALL AREA means a portion of the exterior facade of the building that does not include a substantial material change (paint color is not considered a substantial change); windows or doors; or columns, pilasters or other articulation greater than 12 inches in depth (see also Sec. 3.17.M).

BRACKET SIGN means a sign attached to the ground by one or more support structures that is not higher than 5 feet and hangs from a bracket or support (see also Sec. 5.3.I).

BUILDING ELEMENT means a component of a building as defined in Sec. 3.16.

BUILDING FACADE means the face of a building that delineates the edge of conditioned floor space.

BUILD-TO ZONE means the area on the lot where a certain percentage of the front building facade must be located, measured as a minimum and maximum setback range from the edge of the right-of-way (see also Sec. 3.17.G).

BUILDING TYPE means a building type defined by its form and function in Sec. 3.1.

CABINET SIGN means a sign that is mounted on the face of a building or on the ground that is typically rectangular in shape and provides for internal illumination and changing the message of the sign by replacing a single transparent or translucent panel.

CANOPY SIGN means a sign placed on a canopy so that the display surface is parallel to the plane of the wall (see also Sec. 5.3.J).

CARRIAGE HOUSE means a rear detached accessory dwelling unit located at grade or above a garage that is associated with a detached house building type.

CIVIC BUILDING means a building type that accommodates specifically identified civic uses (see also Sec. 3.1).

COTTAGE COURT means a development building type with 5 to 9 detached houses organized around a common courtyard that fronts a primary street (see also Sec. 3.1).

CROWN SIGN means a wall sign extending not more than 3 feet located on the upper horizontal band of a building at least 55 feet in height (see also Sec. 5.3.K).

DETACHED HOUSE means a building type that accommodates one dwelling unit on an individual lot with yards on all sides along with a rear accessory dwelling unit at grade or above a garage (see also Sec. 3.1).

FORECOURT means an open area at grade or within 30 inches of grade, that serves as an open space, plaza or outdoor dining area (see also Sec. 3.16.F).

GARDEN APARTMENT means a building type that accommodates 3 to 12 attached dwelling units vertically and horizontally integrated (see also Sec. 3.1).

GALLERY means a covered passage extending along the outside wall of a building supported by arches or columns that is open on 3 sides (see also Sec. 3.16.D).

GENERAL BUILDING means a building type that typically accommodates commercial uses (see also Sec. 3.1).

GROSS FLOOR AREA means the sum in square feet of the horizontal area of all floors of the building measured from the exterior walls or from the centerline when two buildings or units abut. Gross floor area includes basement floor area when more than 50% of the basement height is above the established curb level or above the finished lot grade level where the curb level has not been established. Elevator shafts, stairwells, floor space used for mechanical equipment, attics, balconies and mezzanines, enclosed porches and floor area devoted to accessory uses is included in the calculation of gross floor area. However, the

following is not included: any space devoted exclusively to on-site parking; or outdoor loading, display, storage, utility service areas; and uninhabited enclosed space on tops of roofs; or attic space having head room of less than 7'-6".

GROUND FLOOR means the floor of a building that is at or nearest to the level of the ground around the building. Does not include the floor of a basement.

GROUND FLOOR ELEVATION means the height of the finished ground floor measured from the top of the abutting sidewalk (see also Sec. 3.17.J).

GROUND SIGN, SMALL means a sign attached along its entire width to a continuous pedestal that is no higher than 5 feet (see also Sec. 5.3.L).

GROUND SIGN, LARGE means a sign attached along its entire width to a continuous pedestal that is between 5 and 10 feet in height (see also Sec. 5.3.M).

HEIGHT, BUILDING means the highest point of a pitched or flat roof measured from average grade (see also Sec. 3.17.H).

HEIGHT, STORY means the height of story measured from the top of the finished floor to the ceiling above (see also Sec. 3.17.K).

LOT means a parcel of land either vacant or occupied intended as a unit for the purpose, whether immediate or for the future, of transfer of ownership or possession or for development (see also Sec. 3.17.B).

LOT AREA means the area included within the rear, side and front lot lines. Lot area does not include existing or proposed right-of-way, whether dedicated or not dedicated to public use (see also Sec. 3.17.B).

LOT WIDTH means the distance between the two side lot lines measured at the primary street property line along a straight line or along the chord of the property line on a curvilinear lot (see also Sec. 3.17.B).

LOT DEPTH means the distance between the front and rear property lines measured along a line midway between the side property lines (see also Sec. 3.17.B).

IMPROVED SITE AREA means the sum of the horizontal area of the outside portion of the site and includes any space devoted to on-site parking; outdoor loading, display,

storage, utility service, decorative areas and landscaped areas that are part of the original site plan approval.

MIXED USE BUILDING means a multi-story building type that typically accommodates ground floor retail uses with upper-story residential or commercial use (see also Sec. 3.1).

OUTDOOR AMENITY SPACE means a predominately outdoor, open and uncovered area that serves as an outside amenity for occupants of a development (see also Sec. 3.17.F).

PORCH means a raised structure attached to a building, forming a covered entrance to a doorway (see also Sec. 3.16.A).

PROJECTING SIGN means a sign that is wholly or partly dependent upon a building for support, which projects at an angle away from the building, extending more than 1 foot (see also Sec. 5.3.N).

PROTECTED DISTRICT means any R-1A, R-1B, R-1C or R-2 district.

RACEWAY means an enclosed channel of metal or nonmetallic materials designed expressly for holding wires or cables associated with illuminating a sign.

SERVICE STREET means a specifically designated street where special rules apply. 27th Avenue is a designated service street.

SHADE TREE means a locally adapted species with an expected mature height of 35 feet or greater and an expected mature crown spread of at least 30 feet or greater.

SHINGLE SIGN means a small projecting sign that hangs from a bracket or support and is located over or near a building entrance (see also Sec. 5.3.O).

SHOPFRONT BUILDING means a single-story building type that typically accommodates ground floor retail uses (see also Sec. 3.1).

SIDEWALK SIGN means a moveable sign not secured or attached to the ground or surface upon which it is located (see also Sec. 5.3.P).

SITE means any lot or group of contiguous lots owned or controlled by the same person or entity, assembled for the purpose of a single development (see also Sec. 3.17.A).

SITE AREA means the area included within the rear, side and front lot lines of the site. Site area does not include existing or proposed right-of-way, whether dedicated or not dedicated to public use (see also Sec. 3.17.A).

SITE WIDTH means the distance between the side lot lines of the site (generally running perpendicular to a street) measured at the primary street property line along a straight line or along the chord of the property line. (see also Sec. 3.17.A).

STACKED FLAT means a multi-story building type that accommodates side-by-side attached units where units can be used for both non-residential and residential use. Ground floor units can be separated from upper-story units or units can be internally connected (see also Sec. 3.1).

STOOP means a small raised platform that serves as an entrance to a building (see also Sec. 3.16.B).

TOWNHOUSE means a building type that accommodates 3 or more dwelling units where each unit is separated vertically by a common side wall. Units cannot be vertically mixed (see also Sec. 3.1).

TRANSPARENCY means the total area of window and door opening filled with glass, expressed as a percentage of the total facade area by story (see also Sec. 3.17.L).

UNDERSTORY TREE means a locally adapted species with an expected mature height of at least 15 feet and an expected mature crown spread of at least 15 feet.

UPPER STORY means any story above the ground story or floor.

URBAN DEVELOPMENT DIRECTOR means the director of the City of Hattiesburg's Urban Development Department or the director's designee.

WALL SIGN means a sign fastened to or painted on the wall of a building in such a manner that the wall becomes the supporting structure for or forms the background surface of the sign and which does not project more than 1 foot from the building or structure (see also Sec. 5.3.Q).

WINDOW SIGN means a sign affixed to the inside of a window or door or a sign placed within a building so as to be plainly visible and legible through a window or door (see also Sec. 5.3.R).